

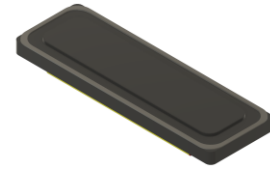

PUI audio



Data Sheet

AS04004MO-SP40

The **AS04004MO-SP40** is a slim line Mobile Series speaker designed for applications that require extended, flat high frequency response and benefit from very low THD.

Features:

- 89dB SPL: 1W dissipation, distance = 0.5m
- 2.0W continuous dissipation
- 400Hz free-air resonance
- 40mm x 13mm x 4.5mm dimensions

Specifications

(Specifications measured with following conditions: ambient temperature; $15^{\circ}\text{C} \leq T_A \leq 35^{\circ}\text{C}$, relative humidity; $25\% \leq RH_A \leq 75\%$, according to standard GB/T9396-1996, unless otherwise stated. Judgement Condition: ambient temperature; $20 \pm 2^{\circ}\text{C}$; relative humidity; $63\% \leq RH_A \leq 67\%$. Product shelf life valid for 12 months.

Parameters	Values	Units
Rated Input Power	2.0	Watts
Maximum Input Power	2.5	Watts
Impedance	$4 \pm 15\%$	Ohms
Sensitivity (SPL) f = ave. 0.8kHz, 1kHz, 1.2kHz, 1.5kHz $P_{DRIVE} = 1.0\text{W}$, 50cm, 5cc back volume $P_{DRIVE} = 1.0\text{W}$, 10cm, 5cc back volume $P_{DRIVE} = 2.0\text{W}$, 10cm, 5cc back volume	75 \pm 3 89 \pm 3 92 \pm 3	dB
Resonant Frequency (f_0) 5cc back volume	400 \pm 20%	Hz
Frequency Range (-10dB SPL)	$f_0 \leq f \leq 20,000$	Hz
Total Harmonic Distortion (THD) f = 1kHz $P_{DRIVE} = 2.0\text{W}$, 5cc back volume	≤ 5	%
Frame Material	PPA	-
Magnet Material	NdFeB	-
Diaphragm Material	Aluminum	-
Weight	7.6	gm
Buzz, Rattle, etc.	Not audible with $P_{DRIVE} = 2\text{W}$, sine wave in free air	-

Polarity	Diaphragm moves forward with positive dc current applied to "+" terminal	-
Storage Temperature	$-25 \leq T_S \leq 60$	°C
Operating Temperature	$-25 \leq T_O \leq 50$	°C
Environmental Compliances	ROHS/REACH	-

Measurement Method (Measured with $P_{DRIVE} = 1.0W$, distance = 0.5m, Temperature: 23 ~ 25°C, Relative Humidity: 55% (max).)

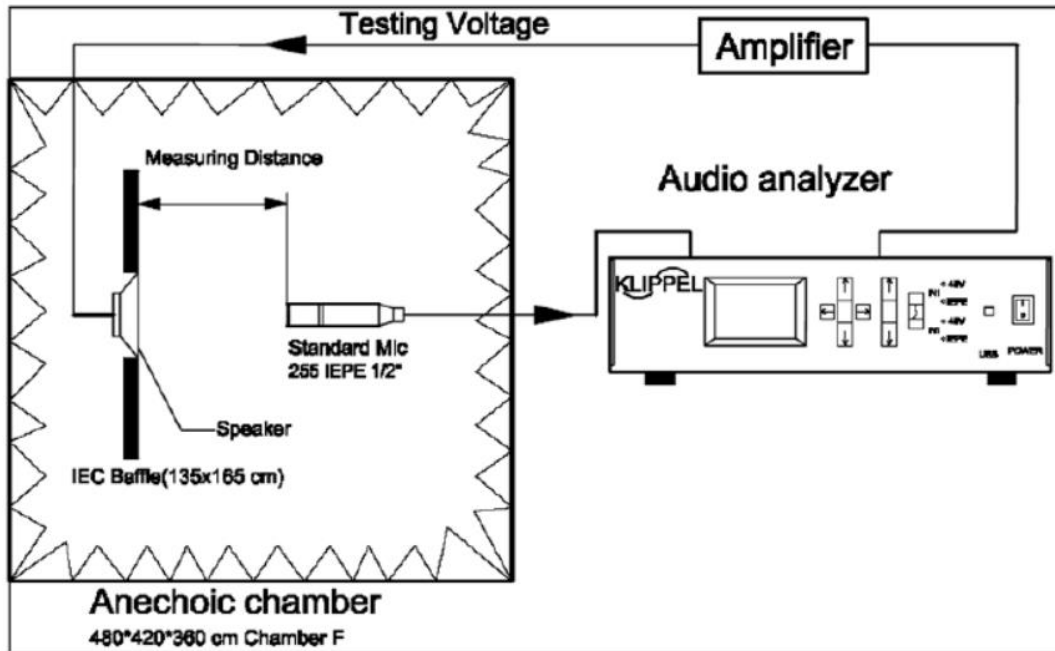

Typical Frequency Response ($P_{DRIVE} = 2.0W$, distance = 0.1m)

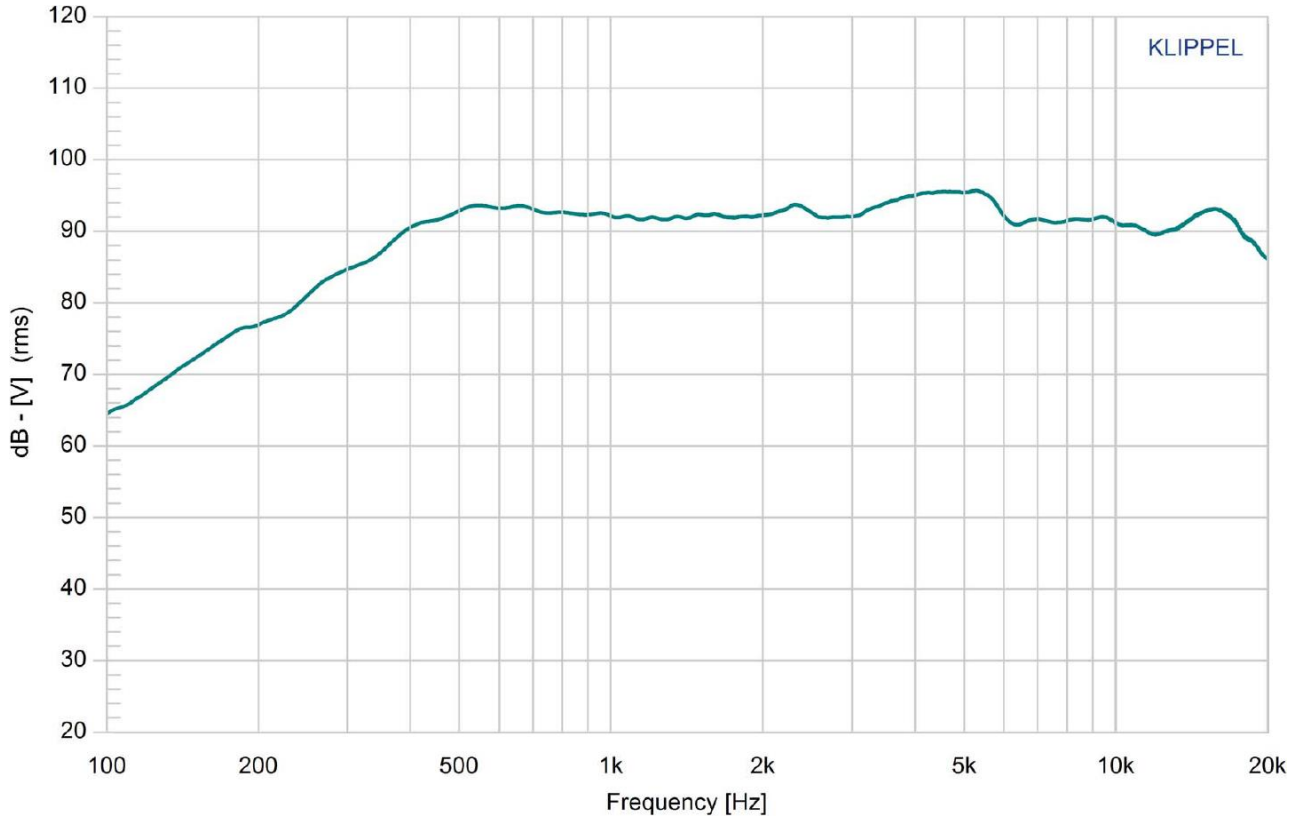

Typical THD vs. Frequency ($P_{DRIVE} = 2.0W$, 5cc back volume)

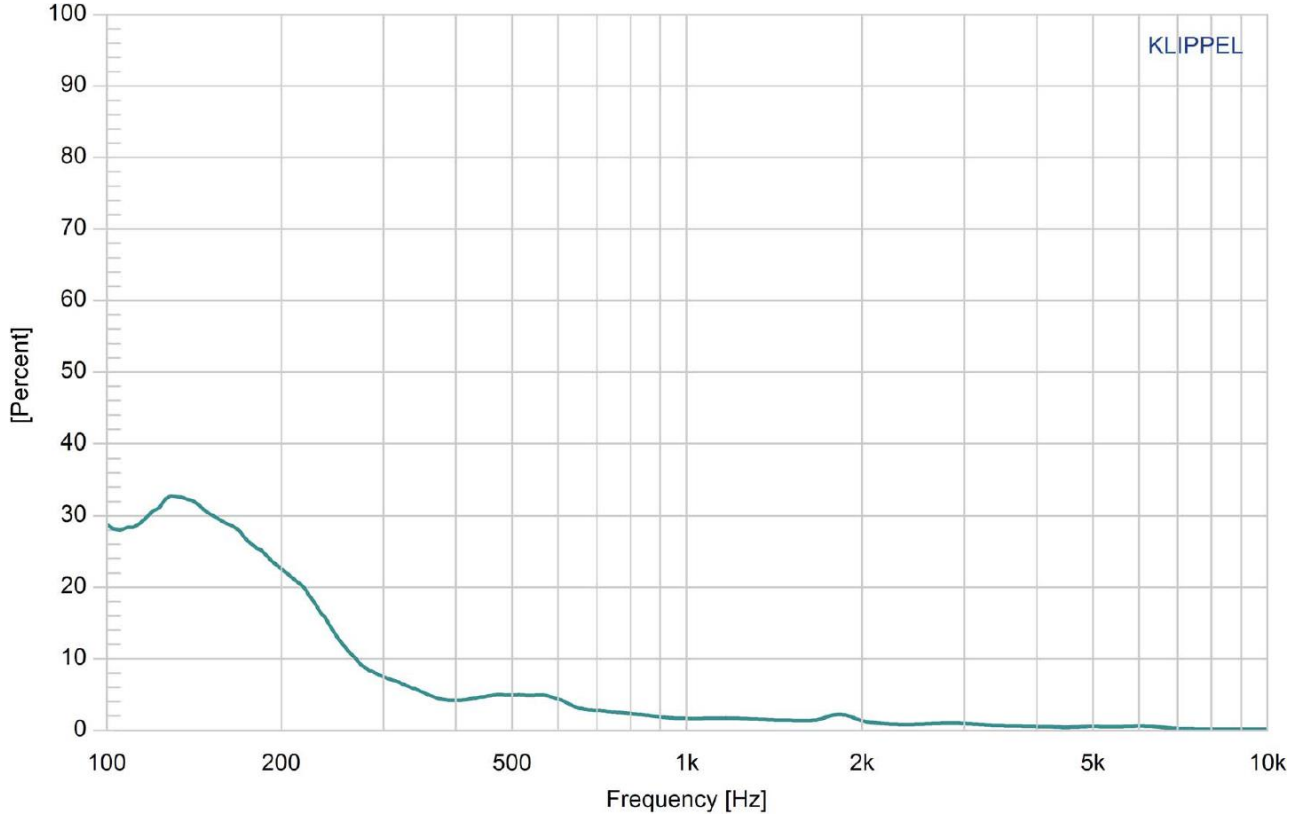

Impedance Curve

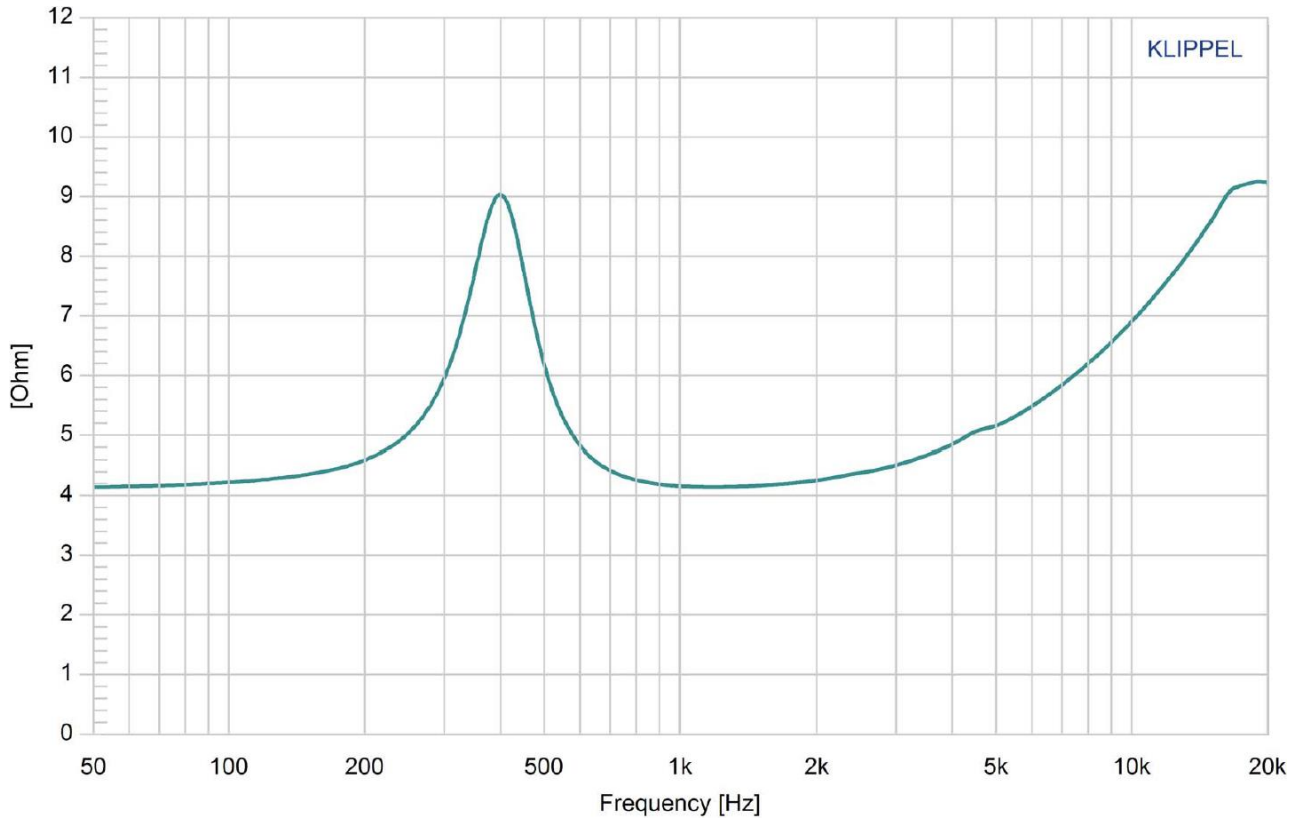

Reliability Testing

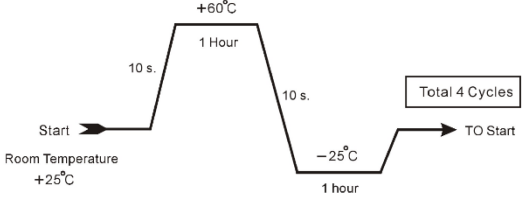
Type of Test	Test Specifications	Judgement
High Temperature Test GB2423.2-81	96 hours at +60°C ± 2°C followed by one hour in normal room temperature	SPL shall not deviate by ±3dB. Resonant frequency shall not deviate by ±50Hz. (compared with pre-test measurement)
Low Temperature Test GB2423.1-81	96 hours at -25°C ± 2°C followed by one hour in normal room temperature	
Humidity Test GB5170.18-87	96 hours at +40°C ± 2°C with relative humidity between 90% and 95% followed by 6 hours in normal room temperature	
Temperature Cycle Testing GB5170.18-87	 <p>The graph shows a temperature cycle starting at Room Temperature +25°C. It ramps up in 10 seconds to +60°C, where it holds for 1 hour. It then ramps down in 10 seconds to -25°C, where it holds for 1 hour. This cycle repeats 4 times before returning to the start.</p>	SPL shall not deviate by ±4dB. Resonant frequency shall not deviate by ±80Hz. (compared with pre-test measurement)
Vibration Test GB11606.8-89	Frequency 30±15 Hz, Amplitude 1.5 mm for 3 Hours	SPL shall not deviate by ±3dB. (compared with pre-test measurement)
Drop Test GB2423.8-81	75 cm free falling on concrete floor, 10 times.	
Load Test GB/T12060.5-2011	Speaker should not fail after applying 20Hz ~ 20kHz pink noise with HPF rated power input (RMS), 96 hours.	

Dimensions (Tolerance: ±0.5mm, unless otherwise specified.)

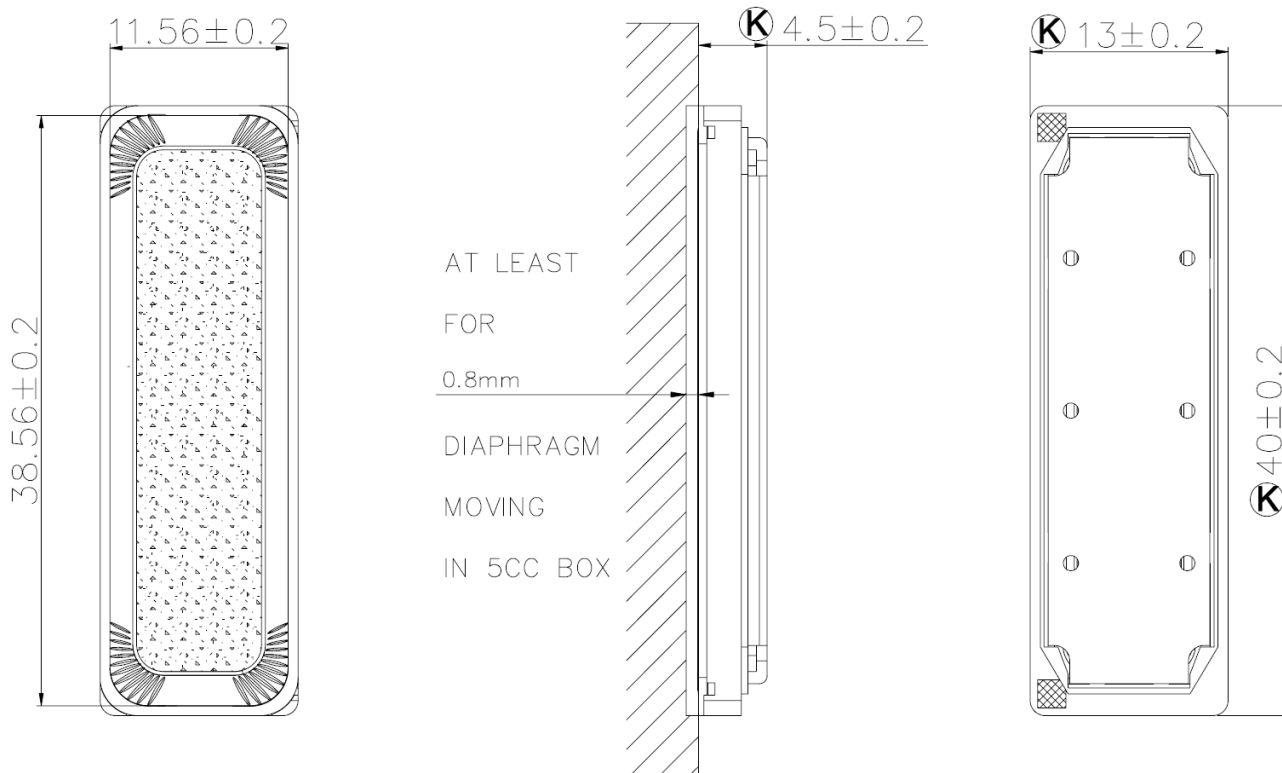

Packaging

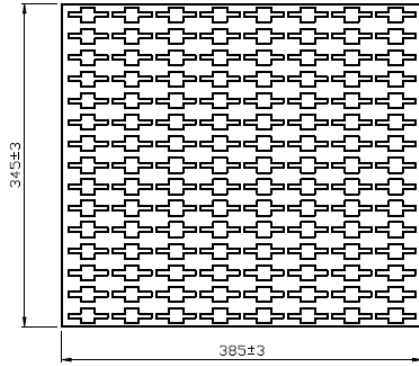

NOTE
120 PCS per Layer
Total 14 Layer per box
Total 1680 PCS per box
紙箱: 41.5*38.5*38.5 cm
HF+ROHS 2

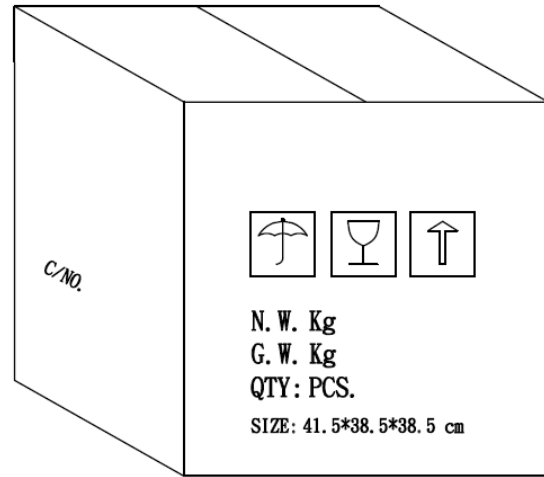
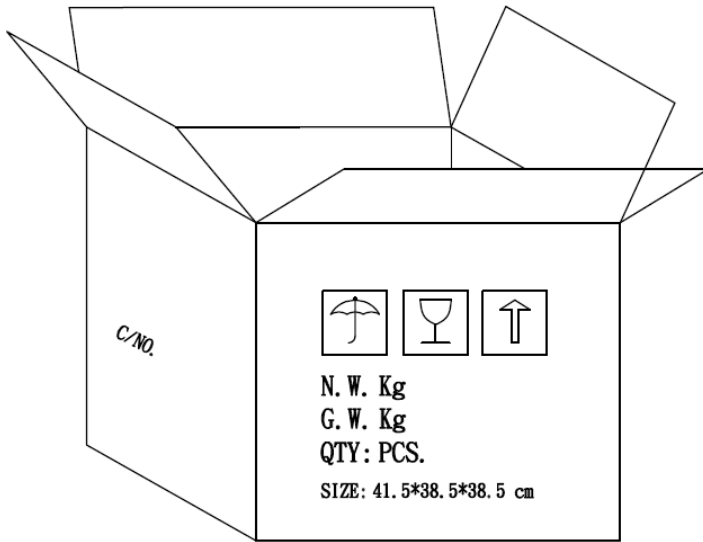

Measurement & Standard Reference

Abstract from GB/T 9396-1996 and IEC 268-5:1989: methods of measurement for main characteristics of loudspeakers.

5.1 Rated sine voltage.

A sinusoidal signal voltage specified by the manufacturer which makes the speaker work continuously in the rated frequency range, without causing electrical or mechanical damage to the speaker. The continuous voltage time is 1 hour.

5.2 Rated sine power.

The rated sine power corresponding with the rated sine voltage defined by: U_s^2/R , where U_s indicates the rated sin voltage and R indicates the rated impedance of the speaker.

5.3 Rated noise power.

The rated sine power corresponding with the rated sine voltage defined by: U_n^2/R , where U_n indicates the rated sin voltage and R indicates the rated impedance of the speaker.

Specifications Revisions

Revision	Description	Date	Approved
A	Released from Engineering	03/25/2024	KH

Notes:

- Unless otherwise specified:
 - All dimensions are in millimeters.
 - Default tolerances are $\pm 0.5\text{mm}$ and angles are $\pm 3^\circ$.
- Specifications subject to change or withdrawal without notice.