



PUIaudio



Data Sheet

HD-PAC0904

Features:

- Fast response time
- High-resolution haptic feedback

Design:

- Emphasized displacement using metal cymbals
- RoHS/REACH exempt PZT ceramics
- Actuator dimensions: 9 x 4 x 1.35 mm (LxWxH)

Specifications

Parameters	Values	Units
Maximum Input Voltage	70	V _{P-P}
Working Voltage Range	-10 ~ +60	-V _P ~ +V _P
Resonant Frequency	34 ± 5	KHz
Resonant Impedance	≤ 80	Ω
Nominal Displacement	12 ± 10%	μM (@ -15V ~ +50V)
Capacitance	160 ± 20%	pF (@1V, 1kHz)
Metal Plate Material	Titanium	-
Soldering Methods	Hand Solder; Low Melting Solder	-
Environmental Compliances	RoHS/REACH	Exempt 7c-1
Weight	0.17	Grams
Storage Temperature	-40 to +70	°C
Operating Temperature	-25 to +60	°C
Operating Humidity	< 75%	Relative Humidity

Dimensions (Units: mm; Polarity: As Marked)

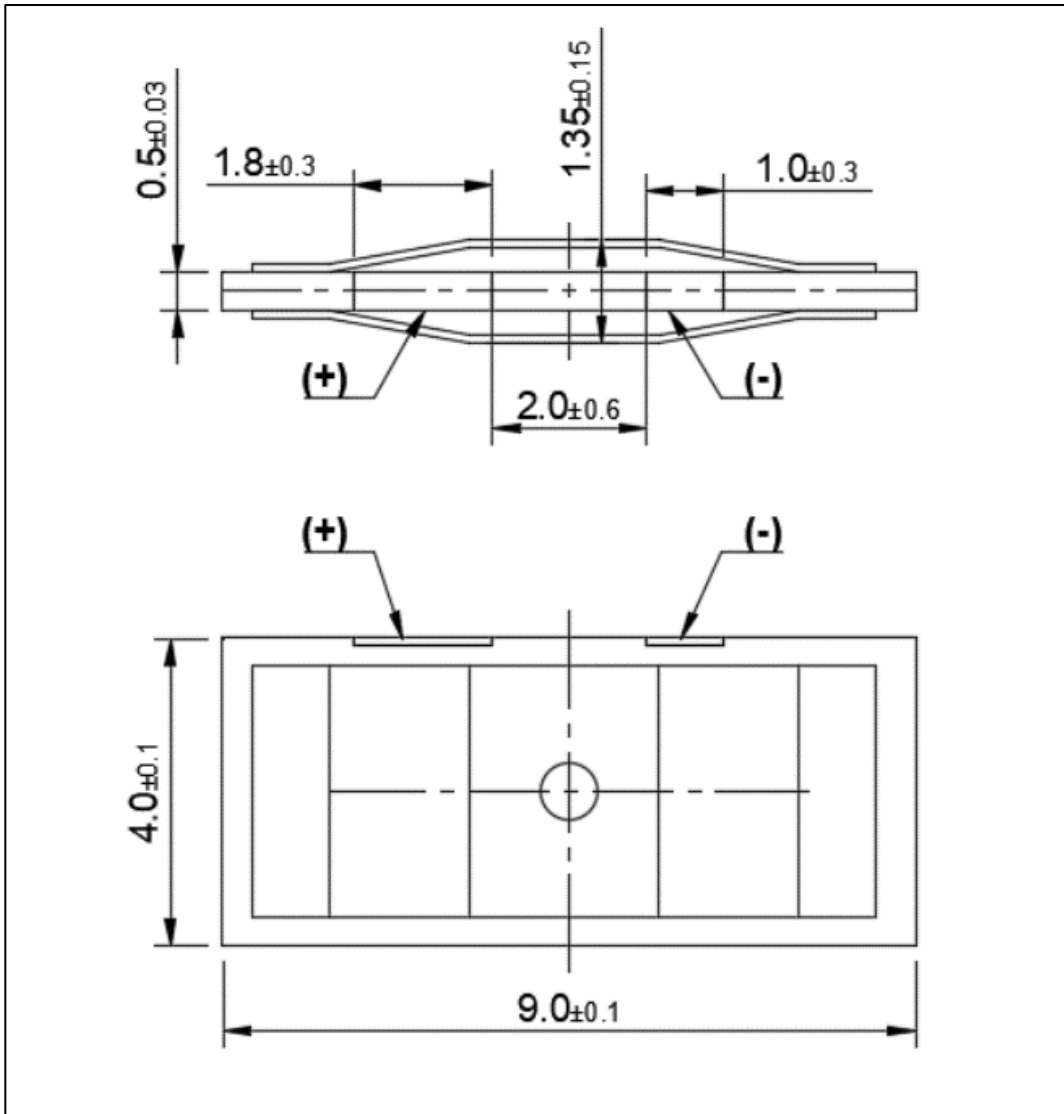

Precautions

Operation:

- 1) Piezoelectric components may generate an impulse voltage when subjected to mechanical or thermal shock.
- 2) During the installation of piezoelectric components, the use of sulfur or sulfide should be avoided as much as possible, which may cause product failure due to corrosion of the surface of the ceramic.
- 3) During the use of piezoelectric components, it is necessary to avoid loading a DC bias voltage exceeding 0.3v (the loading direction should be consistent with the polarization direction, and the time should not exceed 168h) to avoid failure.
- 4) It is recommended to close the piezoelectric components through CRC to protect the sensor during use.
- 5) Piezoelectric components are not moisture absorbing components, and the humidity sensitivity level is Level 1.
- 6) Pb in piezoelectric ceramics is exempt from RoHS within clause 7 (c) - 1.
- 7) Piezoelectric components cannot be repaired during post processing.

Storage:

- 1) Piezoelectric components should be avoided from being used or stored in corrosive gases such as chlorine, sulfur, acid, and alkaline gases. When storing at room temperature and normal humidity, try to avoid direct sunlight and sudden changes in temperature and humidity, which may cause sensor failure.
- 2) The storage of piezoelectric components should be avoided as much as possible under conditions of severe dust and high humidity.
- 3) The recommended storage temperature for the piezoelectric components is $25\pm 5^{\circ}\text{C}$, humidity is 25-65%RH.
- 4) It is recommended to use the piezoelectric components within 7 days after opening the package. If they are not used up, it is necessary to replace the desiccant in the packaging tray and vacuumize the packaging.

Transportation:

- 1) During transportation, piezoelectric components should be protected from sunlight and damp environments.
- 2) Avoid strong impact and vibration on the product during transportation.

Packaging

Pieces per tray / bag	Pieces per master carton
80pcs / TRAY	800pcs / BOX

Specifications Revisions

Revision	Description	Date
A	RELEASED FROM ENGINEERING	04/07/2022

Note:

1. Unless otherwise specified:
 - A. All dimensions are in millimeters.
 - B. Default tolerances are $\pm 0.5\text{mm}$ and angles are $\pm 3^{\circ}$.
2. Specifications subject to change or withdrawal without notice.