

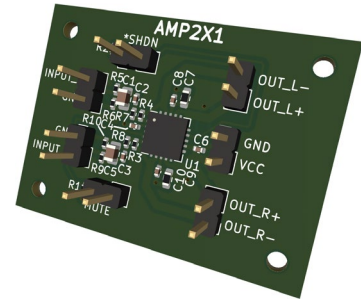

PUIaudio



Data Sheet

AMP2X1 Audio Amplifier Board

PUI Audio's AMP2X1 audio amplifier board features an Analog Device's MAX9710 Class D stereo amplifier integrated circuit for maximum signal fidelity. This amplifier delivers 1.4W per channel into 8Ω loads and 2.6W per channel into 4Ω loads, both at 1% THD+N while using a 5V DC supply.

The board features a small size of 27.9mm x 38.0mm and header pins for easy design prototype development.

Features:

- 1.4W per channel into 8Ω loads, THD < 1%
- 2.6W per channel into 4Ω loads, THD < 1%
- Enhances System Performance that includes
 - Transient suppression when the supply voltage is applied
 - High 100dB PSRR ($V_{RIPPLE} = 200mV_{P-P}$)
- Low quiescent current
 - Extends battery life for portable applications
- Thermal overload protection
- Short-circuit protection
- Power supply range: $4.5V \leq V_{DD} \leq 5.5V$
- 12mA supply current ($V_{DD} = 5.0V$)
- $P_{OUT} = 1.4W$ into 8Ω (THD= 1%, $V_{DD} = 5.0V$)
- $P_{OUT} = 2.6W$ into 4Ω (THD= 1%, $V_{DD} = 5.0V$)
- External resistors adjust the amplifier gain
- 2V Logic-Compatible SHDN Input
- 100mil spaced header pins for input, output, shutdown, power supply, and ground connections

Absolute Maximum Rating

V_{DD} with respect to GND, PGND	6V
PV_{DD} with respect to V_{DD}	$\pm 0.3V$
PGND with respect to GND	$\pm 0.3V$
All other pins with respect to GND	$-0.3V \leq (V_{DD} + 0.3V)$
Continuous Current (any pin except PV_{DD} , PGND, GND, and OUT_{-})	
IN ₋ , \overline{SHDN} , BIAS, TON	$\pm 20mA$
Operating Temperature Range	$-40^{\circ}C \leq T_A \leq 85^{\circ}C$
Storage Temperature Range	$-65^{\circ}C \leq T_A \leq 150^{\circ}C$

Electrical Characteristics

($V_{DD} = 5.0V$, $V_{GND} = 0V$, $\overline{SHDN} = V_{DD}$, GAIN = V_{DD} (0dB), $C_{BIAS} = 0.1\mu F$, $C_{IN} = 0.47\mu F$, no load: $R_{IN} = R_F = 15k\Omega$, $T_A = t_{MIN} \leq t \leq t_{MAX}$. Typical values are given at $T_A = 25^{\circ}C$, unless otherwise noted.)

Parameter	Conditions	Minimum	Typical	Maximum	Unit
Power Supply Voltage Range	Guaranteed by the PSRR test	4.5		5.5	V
Quiescent Power Supply Current			12		mA
	$\overline{SHDN} = 0V$		0.5		μA
Output Power	$V_{DD} = 5.0V$, 1% THD+N (Note 1)	$R_L = 8\Omega$	1.4		W
		$R_L = 4\Omega$	2.6		
Total Harmonic Distortion + Noise	$f_{IN} = 1kHz$, $BW = 22Hz \leq f \leq 22kHz$	$R_L = 8\Omega$ $P_{OUT} = 1.2W$	0.005		%
		$R_L = 4\Omega$ $P_{OUT} = 2W$	0.01		
Signal-to-Noise Ratio	A-weighted, $V_{OUT} = 2.8V_{RMS}$, $BW = 22Hz \leq f \leq 22kHz$, Input-referred		95		dB
Channel-to-Channel Crosstalk	$f_{IN} = 10kHz$, Input-referred		-77		dB
Maximum Capacitive Load Drive			1000		pF
Power Supply Rejection Ratio	$V_{RIPPLE} = 200mV_{P-P}$ (Note 1)	$4.5V \leq V_{DD} \leq 5.5V$	82	100	dB
		$f = 1kHz$		87	
		$f = 20kHz$		74	
Thermal Protection Threshold			160		$^{\circ}C$
Thermal Protection Hysteresis			15		$^{\circ}C$
Logic Input Voltage High		2			V
Logic Low Voltage Low				0.8	

Note 1: Power Supply Rejection Ratio is specified with the amplifier inputs grounded through C_{IN} and R_{IN} .

Typical Performance Characteristics

($V_{DD} = 5.0V$, $V_{GND} = 0V$, $\overline{SHDN} = V_{DD}$, GAIN = GND ($R_F = R_{IN} = 10k\Omega$), $C_{BIAS} = 1.0\mu F$, $C_{IN} = 2.2\mu F$, no load, unless otherwise noted.)

TOTAL HARMONIC DISTORTION PLUS NOISE vs. FREQUENCY

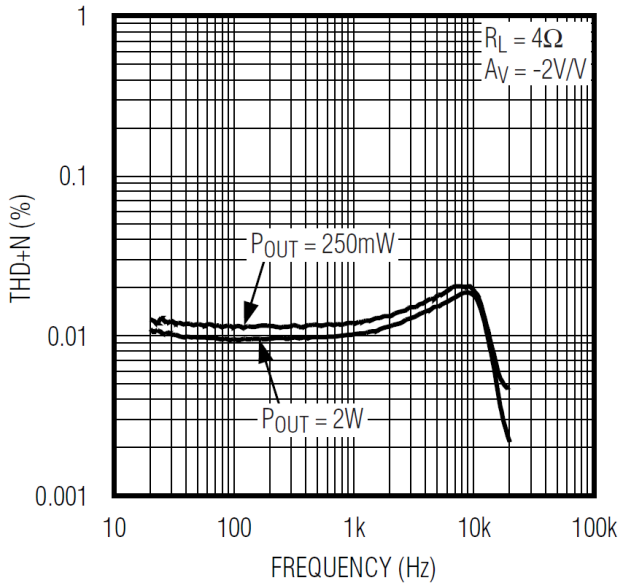

TOTAL HARMONIC DISTORTION PLUS NOISE vs. FREQUENCY

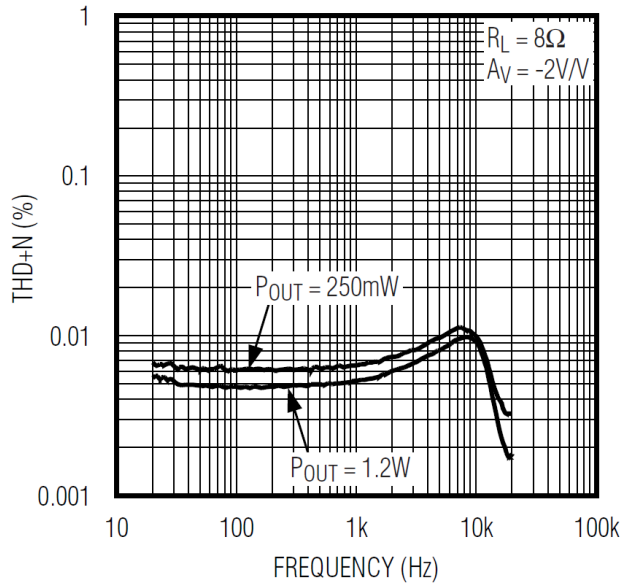

TOTAL HARMONIC DISTORTION PLUS NOISE vs. OUTPUT POWER

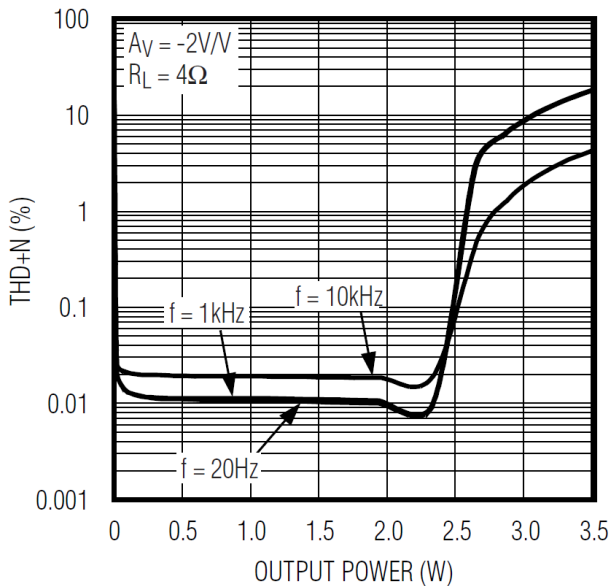

TOTAL HARMONIC DISTORTION PLUS NOISE vs. OUTPUT POWER

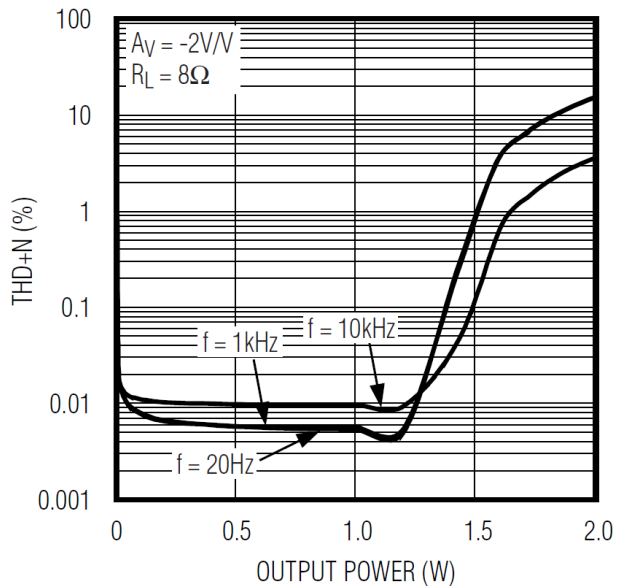

POWER DISSIPATION vs. OUTPUT POWER

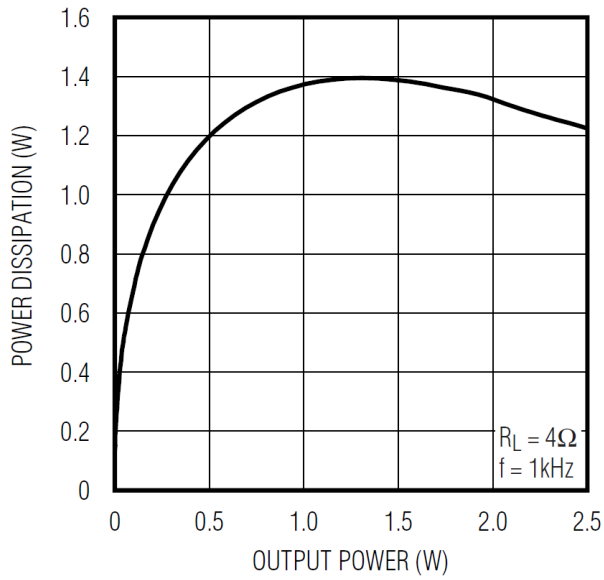

POWER DISSIPATION vs. OUTPUT POWER

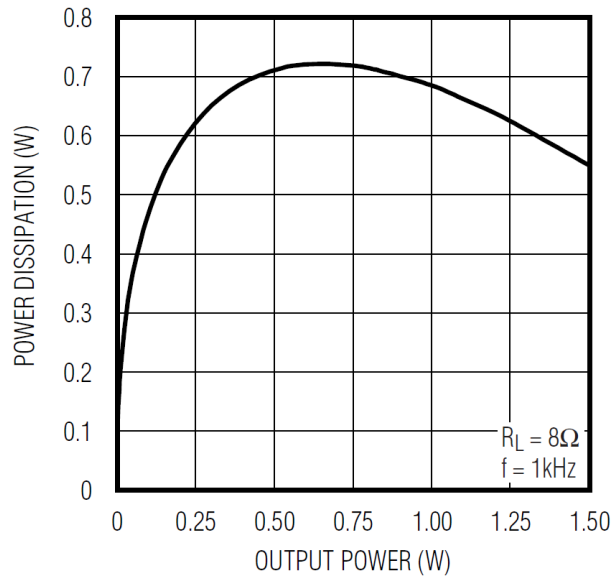

SUPPLY CURRENT vs. SUPPLY VOLTAGE

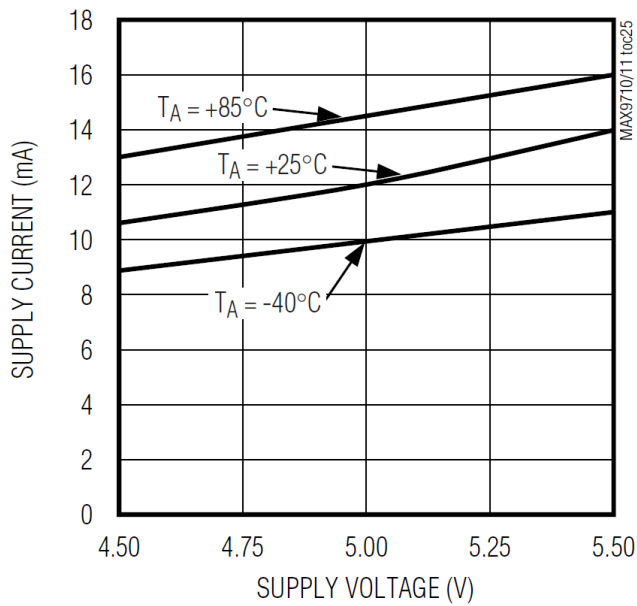

Detailed Description

The AMP2X1 audio amplifier board uses the MAX9710 stereo 1.4W (8Ω) Class AB audio amplifier. This amplifier offers low, 12mA (typical, $V_{DD} = 5V_{DC}$), an excellent 110dB (typical) SNR, and high linearity expressed in its 0.005% THD+N. The amplifier features circuitry that produces high suppression of output transients when the power supply voltage is applied. Additionally, the amplifier's power supply rejection ratio (PSRR) is an outstanding 100dB.

The AMP2X1's amplifier's closed-loop gain is set by the value of external resistors.

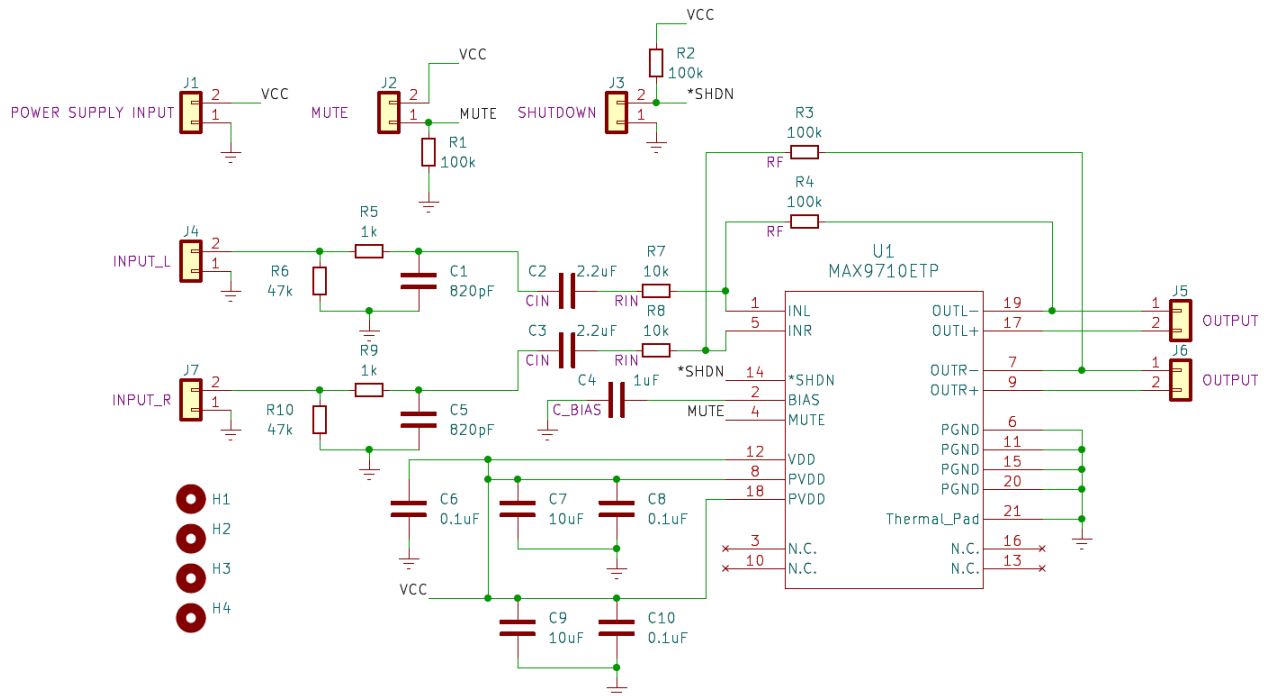

Figure 1. AMP2X1 schematic.

Bias

The AMP2X1's amplifier operates with a single 4.5V to 5.5V power supply voltage. It uses internal circuitry to generate the $V_{DD}/2$, ground-referenced common-mode bias voltage. This circuitry suppresses the output transients during supply voltage application while it sets the amplifier outputs' DC-bias level. The BIAS circuitry's output is available on the BIAS pin so that an external capacitor can be connected between this pin and GND, allowing for the connection of a decoupling capacitor. The value of this capacitor is chosen based on the recommendations detailed in the **BIAS Capacitor** section below. To ensure proper amplifier operations, do not connect any load to the BIAS pin. Doing so will compromise the amplifier's overall operation.

Shutdown Mode

The AMP2X1 features a low-power shutdown mode that, when activated, reduces power supply current to a nominal 0.5µA. When shutdown mode is active, the internal bias circuitry is disabled, the amplifier's outputs change to a high impedance state, and the BIAS pin output is equal to GND.

MUTE

The AMP2X1 features a MUTE function that features clickless and popless operation when activated or deactivated. When activated by connecting the MUTE pin to the power supply voltage present at Pin 4, the amplifier's inputs are internally disconnected from the amplifier power stages. The amplifier is only muted, and not shutdown. The amplifier is unmuted when the MUTE pin is connected to ground.

Suppressing Amplifier Output Transients

The AMP2X1's MAX9710 features a leading-edge transient suppression circuit that ensures that output transients' magnitude the occur when the power supply voltage is applied to the amplifier are minimized. This is a result of controlling the slew rate of the bias circuitry's output voltage's magnitude changes to $V_{DD}/2$. Conversely, when shutdown is activated, the impedance of amplifier's outputs is set to a high impedance. Both functions work together to ensure that transient energy in the audio bandwidth is suppressed and minimized.

Optimum output transient suppression results when

$$R_{IN} \times C_{IN} < R_{BIAS} \times C_{BIAS}$$

where $R_{BIAS} = 50k\Omega$.

BTL Amplifier Output

The AMP2X1's amplifier is designed to differentially drive loads connected between the OUT+ and OUT- pins. This is a bridge-tied-load (BTL). This configuration has advantages over a single-ended, ground referenced load. Differential output drive doubles the output voltage across the load when compared by the drive voltage across a single-ended load.

Doubling the voltage applied across a load quadruples the power dissipated by the load. The peak-to-peak voltage swing across a single-ended load is expressed by Eq. 1. The peak-to-peak voltage swing across a BTL-connected load is expressed by Eq. 2 and Eq. 3. The power dissipated by a single-ended-connected load is expressed by Eq. 4. The power dissipated by a BTL-connected load is expressed by Eq. 5.

$$V_{RMS_SE} = \frac{V_{OUT\ p-p}}{2\sqrt{2}} \quad \text{Eq. 1}$$

$$V_{RMS_BTL} = \frac{2V_{OUT\ p-p}}{2\sqrt{2}} \quad \text{Eq. 2}$$

$$V_{RMS_BTL} = \frac{V_{OUTp-p}}{\sqrt{2}} \quad \text{Eq. 3}$$

$$P_{OUT_SE} = \frac{V_{RMS_SE}^2}{R_L} \quad \text{Eq. 4}$$

$$P_{OUT_BTL} = \frac{V_{RMS_BTL}^2}{R_L} \quad \text{Eq. 5}$$

For a 5Vp-p output voltage swing, the dissipation in an 8Ω load is 0.391W.

When the load is applied across two identical amplifiers whose outputs are 180degrees out-of-phase, the output voltage swing is 10Vp-p. This results in a dissipation across the same 8 Ω load that is 1.56W, or four times that dissipated by a single-ended load.

Although each amplifier is biased to one-half of the power supply voltage, since the voltage with respect to ground is the same on each output, there is no net differential DC voltage applied across the load. There is, therefore, no need to use any DC-blocking capacitors in series between the amplifier's outputs and the load. This is unlike a single-ended amplifier, which must have a DC-blocking capacitor when the single-ended output and the ground terminated load. DC-blocking capacitors used with single-ended amplifiers and very low resistances will typically have high values, large size, and can degrade low-frequency response and performance.

Amplifier Gain

The AMP2X1's two audio amplifiers use external resistors (R3-R8, right channel and R4-R7, left channel) to set the desired closed loop gain. The MAX9710's gain is set using Eq. 5.

$$A_V = 2 \left(\frac{R_F}{R_{IN}} \right) \quad \text{Eq. 5}$$

Referring to Figure 1 with $R_{IN} = 10k\Omega$ and $R_F = 100k\Omega$, the gain is 20V/V or 26dB.

Input Filter

The AMP2X1 uses AC-coupling capacitors, C_{IN} , in series with both differential inputs. These capacitors allow the MAX9710's inputs to internally bias to the optimum DC level, nominally $0.5V_{CC}$. Assuming a zero-source impedance, the combination of the input resistor, R_{IN} , and coupling capacitor C_{IN} , forms a high-pass filter that has a cutoff frequency as defined by Eq. 4.

$$f_{-3dB} = \frac{1}{2\pi R_{IN} C_{IN}} \quad \text{Eq. 4}$$

Setting the f_{-3dB} frequency too high can compromise the low frequency performance. This frequency is dependent on the frequency bandwidth design targets for the system in which the AMP2X1 is used.

Capacitor chemistry recommendations include selecting devices with low voltage coefficients such as film capacitors or NPO or X7R ceramic devices. It is best to use high voltage ratings beyond 20V.

BIAS Capacitor

The BIAS pin is internally connected to the circuitry that generates the $V_{DD}/2$ bias voltage. This connection allows connecting a capacitor between the internal bias voltage generator and ground. This capacitor reduces power supply and other source noise present at the common-mode node, maximizing the PSRR and THD+N performance. This capacitor is also used by the bias generator circuitry to produce a controlled slew rate bias voltage waveform that ensures transient suppression at the amplifier outputs. This capacitor's minimum value is $0.1\mu\text{F}$ and can use higher values up to $1\mu\text{F}$ to maximize PSRR.

Power Supply Bypassing

The AMP2X1 uses proper supply capacitive bypassing to ensure low-noise, low-distortion audio performance. Whereas the suggested bypass device is a $0.1\mu\text{F}$ ceramic capacitor connected between the V_{DD} pin and GND, the AMP2X1 uses an additional $10\mu\text{F}$ bulk capacitance in parallel with a $0.1\mu\text{F}$ capacitor. The bypass capacitance is placed as close as possible to the PV_{DD} and V_{DD} pins.

AMP2X1 Controls, Input, Outputs, and Settings

The AMP2X1 features the following controls, input, output, and settings.

Jumper J1 is the AMP2X1's power supply voltage input. Apply a DC voltage in the range of $4.5V_{DC}$ to $5.5V_{DC}$. Apply the positive voltage to the V_{DD} pin (pin 2) and apply ground to the GND pin (pin 1).

Jumper J2 controls the amplifier's MUTE function. The default setting is the jumper is open, pulling the active-high MUTE input to a logic low, allowing full operation. When mute is desired, the MUTE pin is pulled high by placing a short between pin 1 and pin 2.

Jumper J3 controls the amplifier's shutdown (SHDN) function. The default setting is the jumper is open, pulling the active-low $\overline{\text{SHDN}}$ input to a logic high, allowing full operation. When shutdown is desired, place a short between pin 1 and pin 2. When shutdown is active, the amplifier output's change to a high-impedance state, and the power supply current drops to a nominal $0.5\mu\text{A}$.

Jumper J4 provides the connection node for the single-ended **left-channel** audio signal input. The audio signal is applied to V_{IN} pin (pin 2) and the input signal's ground reference is applied to GND (pin 1).

Jumper J5 is the AMP2X1's **left-channel** BTL amplifier output. Connect a load across the jumper's pin 1 and pin 2. Pin 1 is the inverting output, whereas pin 2 is the non-inverting output.

Jumper J6 is the AMP2X1's **right-channel** BTL amplifier output. Connect a load across the jumper's pin 1 and pin 2. Pin 1 is the inverting output, whereas pin 2 is the non-inverting output.

Jumper J7 provides the connection node for the single-ended **right-channel** audio signal input. The audio signal is applied to V_{IN} pin (pin 2) and the input signal's ground reference is applied to GND (pin 1).

The input signal's voltage magnitude is predicated on the power supply voltage and the closed-loop gain set by resistors R4-R7 and R3-R8. As configured, the AMP2X1 has a 20x (26dB) closed-loop gain. For example, when using a 5V power supply voltage, the output voltage is nominally $3.35V_{RMS}$ when driving an 8Ω loads and $3.22V_{RMS}$ when driving 4Ω loads. These voltages translate into $4.74V_{PEAK}$ and $4.55V_{PEAK}$, respectively. With the AMP2X1's nominal gain, the peak input voltage levels are, respectively, $0.24V_{PEAK}$ and $0.23V_{PEAK}$ or $0.17V_{RMS}$ and $0.16V_{RMS}$. At these levels, the THD will typically not exceed 1%.

Dimensions

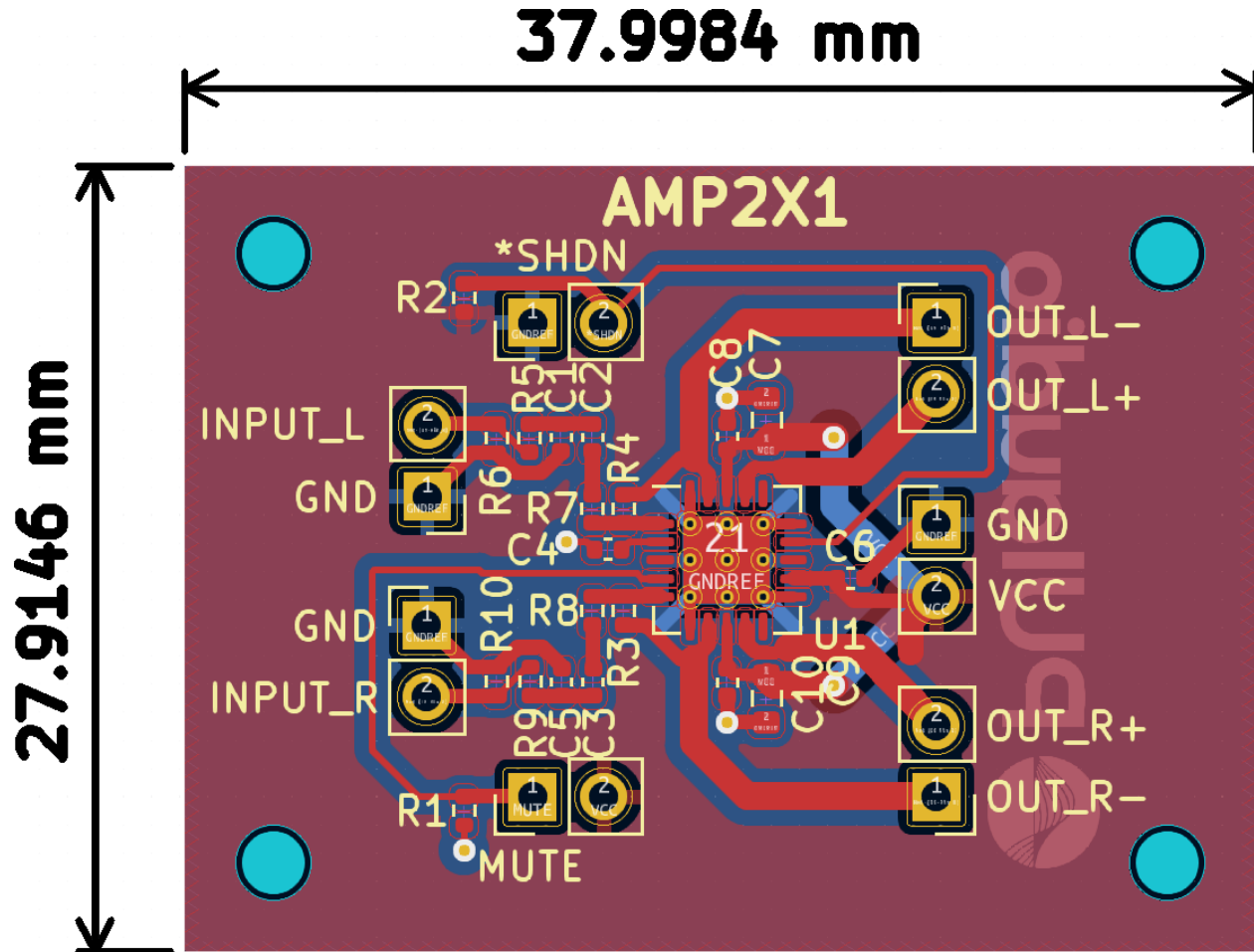

Packaging

One box that contains one two-channel, 1W per channel amplifier board and through-hole headers contained within an ESD-protective bag.

Specifications Revisions

Revision	Description	Date	Approved
A	Datasheet released from Engineering	11/16/2024	KH

Note:

- Unless otherwise specified:
 - All dimensions are in millimeters.
 - Default tolerances are $\pm 0.5\text{mm}$ and angles are $\pm 3^\circ$, unless otherwise specified.
- Specifications subject to change or withdrawal without notice.