

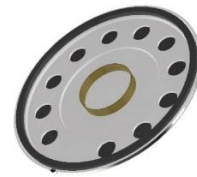

# PUI audio



Data Sheet

AS05045MR-R

## Specifications

Parameters	Values	Units
Rated Input Power	1.0	Watts
Max Input Power	1.5	Watts
Impedance	45 ± 15%	Ohms
Output SPL (Avg. 0.6, 0.8, 1.0, 1.2kHz @ 1.5W/0.1m)	97 ± 3	dB
Resonant Frequency ( $f_0$ )	350 ± 20%	Hz
Frequency Range (-10dB SPL)	$f_0 \sim 20,000$	Hz
THD (1kHz, 1.5W Drive)	≤5	%
Diaphragm Material	Mylar	-
Frame Material	Metal	-
Magnet Material	NdFeB (N35)	-
Weight	11.6	Grams
Buzz, Rattle, etc.	Must not be audible with $f_0 - 5\text{kHz}$ , 1.5W sine wave	-
Environmental Compliances	ROHS/REACH	-
Polarity	Cone moves forward with positive dc current applied to "+" terminal	-
Storage Temperature	-30 ~ +60	°C
Operating Temperature	-20 ~ +60	°C

## Measurement Method (Measured with 1.5W, L = 0.1m, Temperature: 23 ~ 25°C, Relative Humidity: 55% (max).)

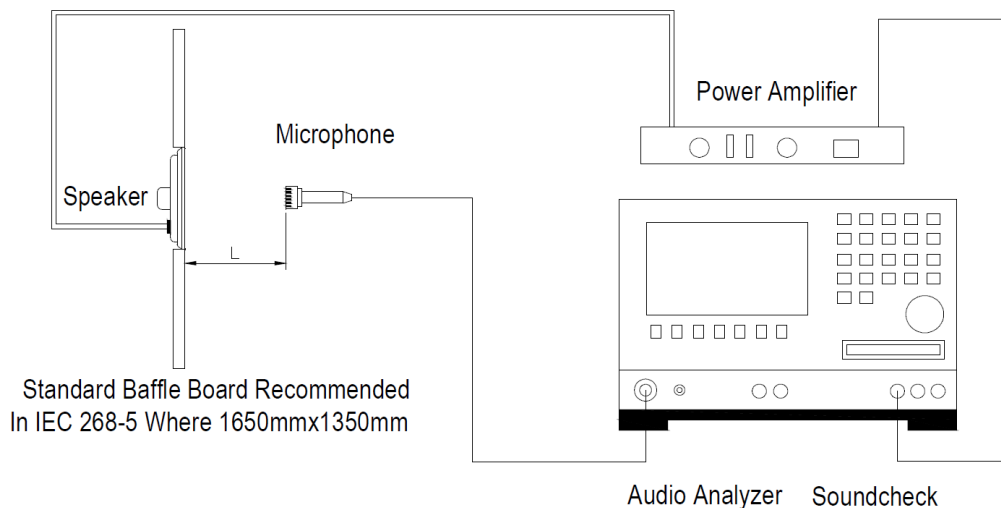

## Typical Frequency Response (Measured with 1.5W drive, distance = 0.1m)

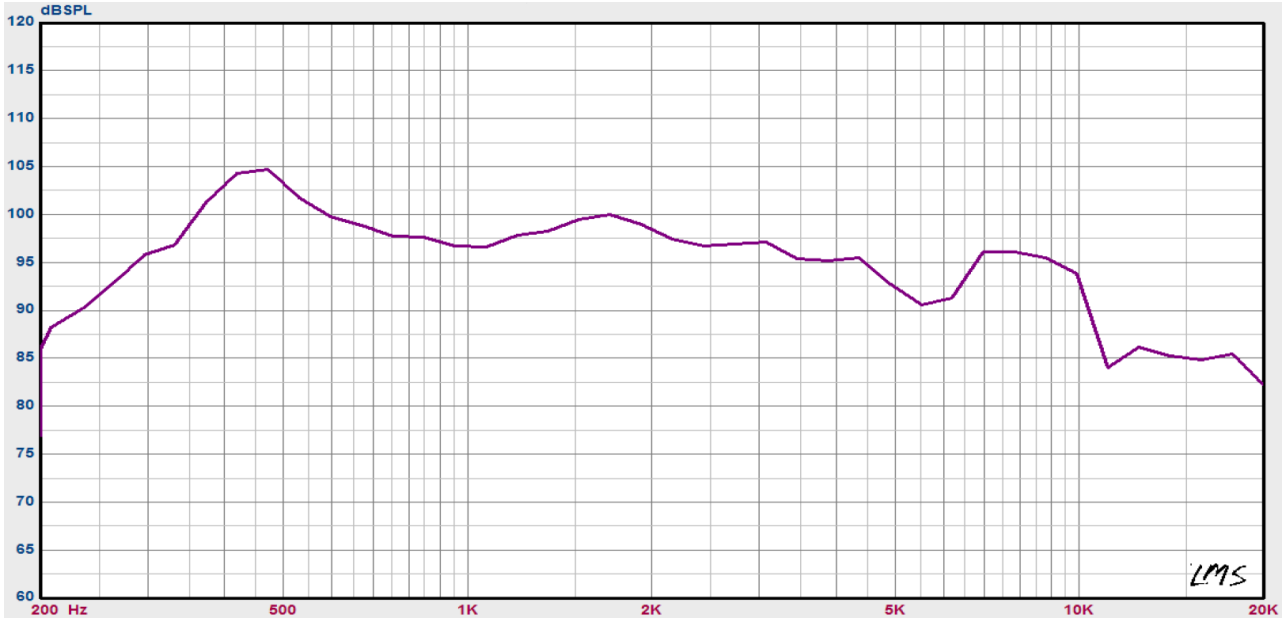

## Reliability Testing

Type of Test	Test Specifications
High Temperature Test	96 hours at 60±3°C
Low Temperature Test	96 hours at -30±3°C
Humidity Test	96 hours at 30±3°C with relative humidity at 92~95%
Temperature Cycle Testing	Run for 5 cycles with each cycle consisting of: 
Vibration Test	Frequency: 10~55~10Hz Oct/min Amplitude: 1.5mm Duration: 2 hours each of 3 perpendicular directions
Drop Test	Drop the speaker contained in normal box onto the surface of 40mm thick board 10 times from the height of 75cm.
Load Test	Must perform normal with program White-Noise source at Rated Power for 96 Hours

After each test let rest for 6 hours in standard room temperature, the part shall be within ±3dB.

### Dimensions (Tolerance: $\pm 0.5\text{mm}$ , unless otherwise specified.)

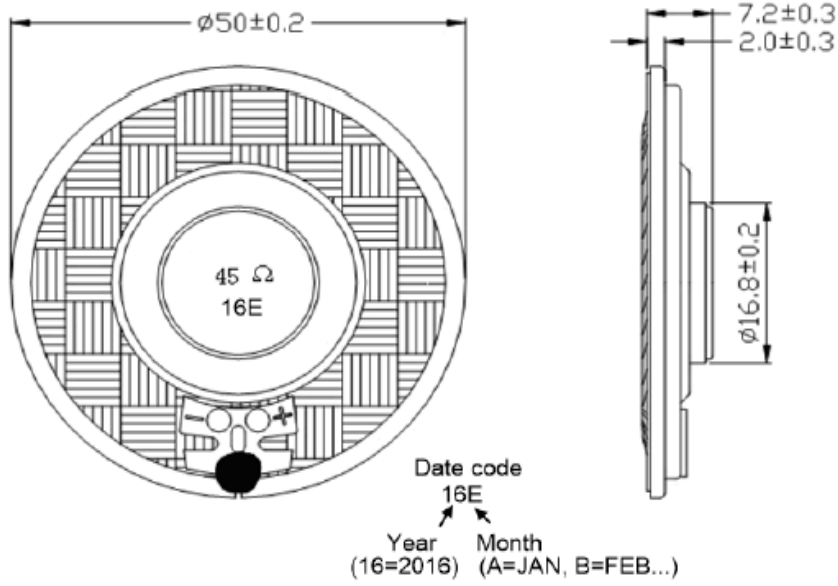

### Packaging

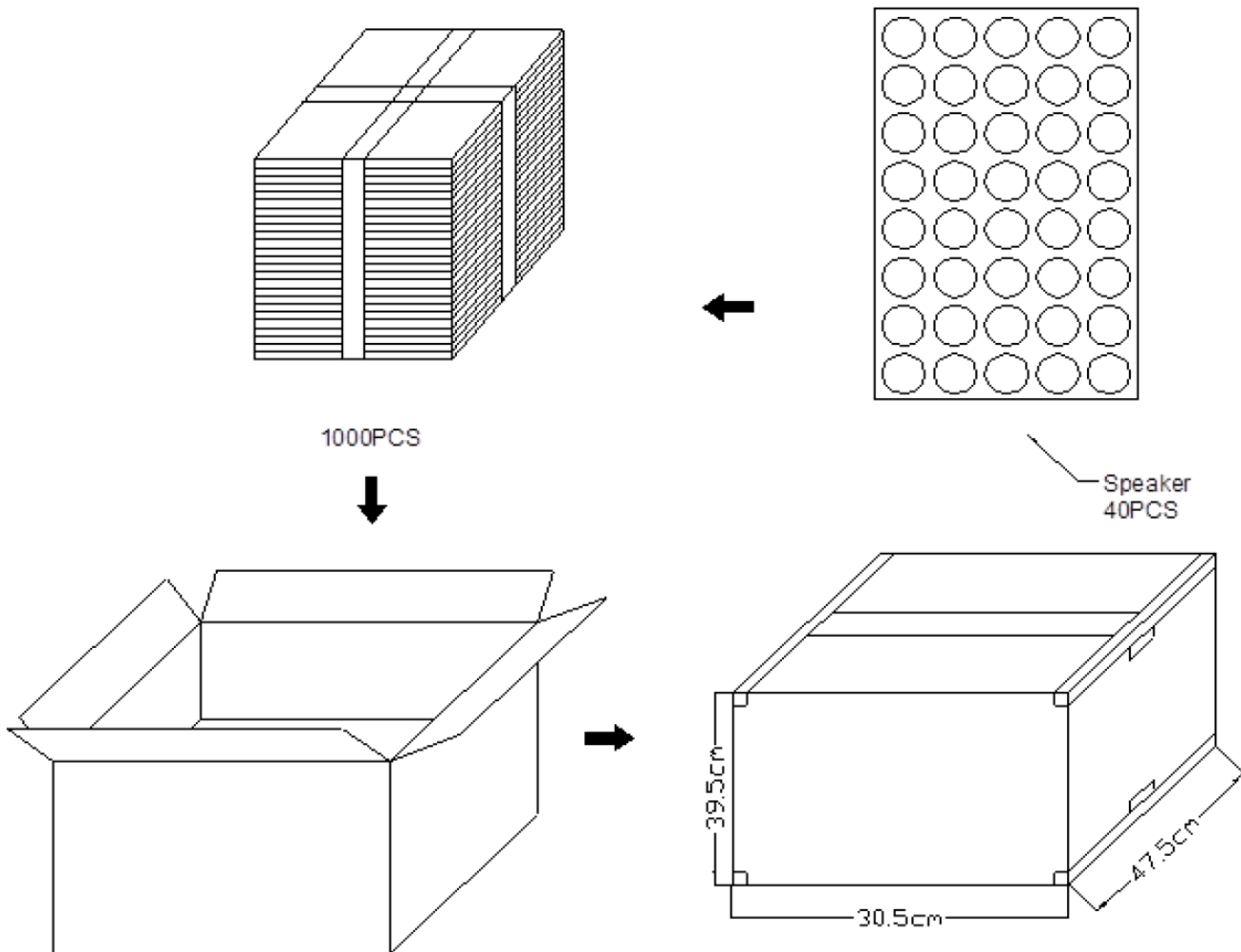

**Specifications Revisions**

<b>Revision</b>	<b>Description</b>	<b>Date</b>	<b>Approved</b>
-	Released from Engineering	11/09/2015	-
A	Revised SPL from 102dB to 97dB	05/27/2016	ML
B	Revised Frequency Range to 20kHz	07/27/2023	-

Note:

1. Unless otherwise specified:
  - A. All dimensions are in millimeters.
  - B. Default tolerances are  $\pm 0.5\text{mm}$  and angles are  $\pm 3^\circ$ .
2. Specifications subject to change or withdrawal without notice.