



PUI audio



Data Sheet

SMT-0540-S-R

Features:

- 5x5mm SMT magnetic transducer
- 3V0-p, 4kHz

Specifications

Parameters	Values	Units
Rated Voltage	3	V0-p
Operating Voltage Range	2 ~ 4	V0-p
Current Draw at Rated Voltage*	100	mA
Coil Resistance	12 ± 2	Ohms
Minimum SPL @ 10cm*	78	dBA
Resonant Frequency	4,000 ± 500	Hz
Housing Material	LCP	-
Terminal Material	Au plated PBC	-
Weight	0.1	Grams
Acceptable Soldering Methods	Hand Solder @ 350C for 5s, Reflow Solder	See following pages for reflow solder information
Environmental Compliances	RoHS/REACH	-
Moisture Sensitivity Level (MSL)	2	-
Operating Temperature	-30 ~ +70	°C
Storage Temperature	-40 ~ +85	°C

*At rated voltage with 50% duty cycle 4 kHz positive biased square-wave

Recommended Drive Circuit (Transistor should have a $V_{ce} \leq 0.15V$ and $h_{FE} \geq 200$)

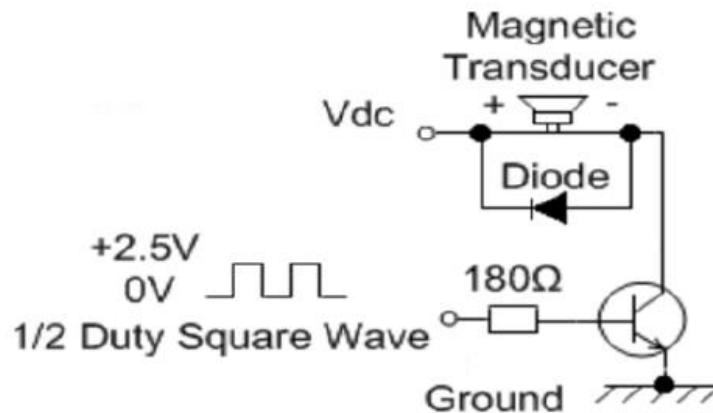

Test Condition

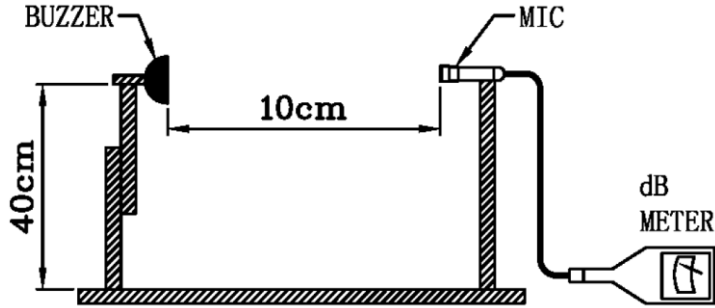

Typical Frequency Response (3V input measured at 10cm)

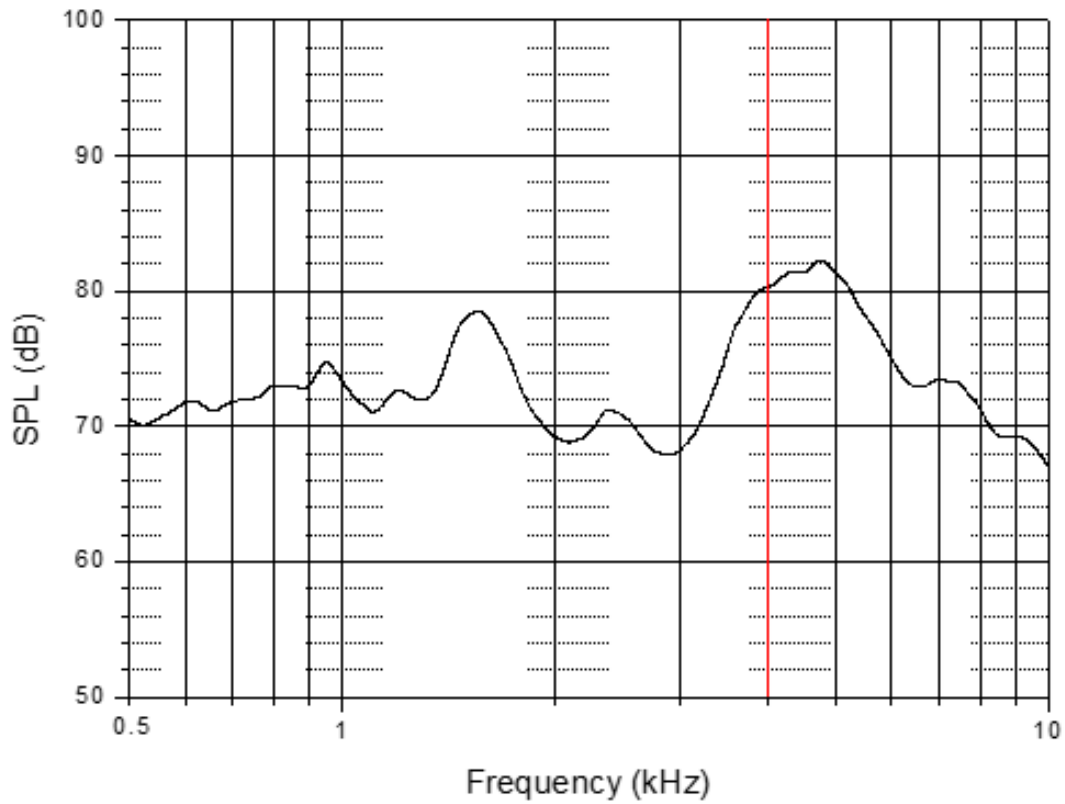

Reliability Testing

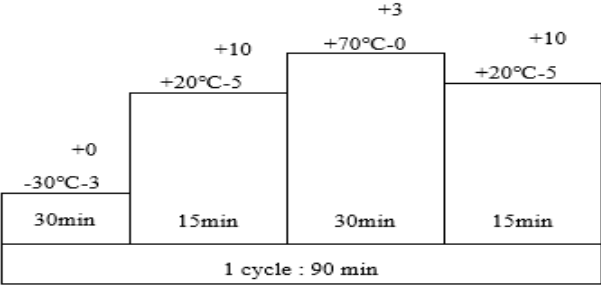
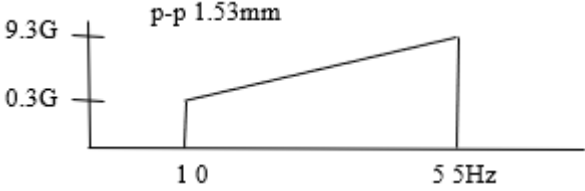
Type of Test	Test Specifications
High Temperature Test	The part shall be capable of withstanding a temperature +85°C for 96 hours
Low Temperature Test	The part shall be capable of withstanding a temperature -40°C for 96 hours
Life Test	Continuous operation for 1000hrs, 3V0-p, 4kHz square wave using drive circuit.
Temperature Cycle Testing	<p>Total 5 cycles of the following without power.</p>  <p>The diagram shows a temperature cycle profile with four steps: 1. -30°C-3 for 30min; 2. +20°C-5 for 15min; 3. +70°C-0 for 30min; 4. +20°C-5 for 15min. The total cycle time is 90 minutes. Above the steps are labels: +0 above the first step, +10 above the second, +3 above the third, and +10 above the fourth.</p>
Vibration Test	 <p>The diagram shows a sine wave profile with a peak-to-peak amplitude of 1.53mm. The vertical axis is labeled with 0.3G and 9.3G. The horizontal axis is labeled with 10 and 5 Hz.</p> <p>Test for direction of X, Y, Z for 2 hours each (6hrs total).</p>
Drop Test	Affix transducer on PCB to weight of 100g. Drop 120cm to direction of 6 surfaces for 3 cycles.
Solderability	Solder bath temp 235°C ± 5°C, time 2 ± 0.5 sec

After each test, part shall meet specifications with an SPL variance that of specification tolerance.

Recommended Reflow Soldering Procedure

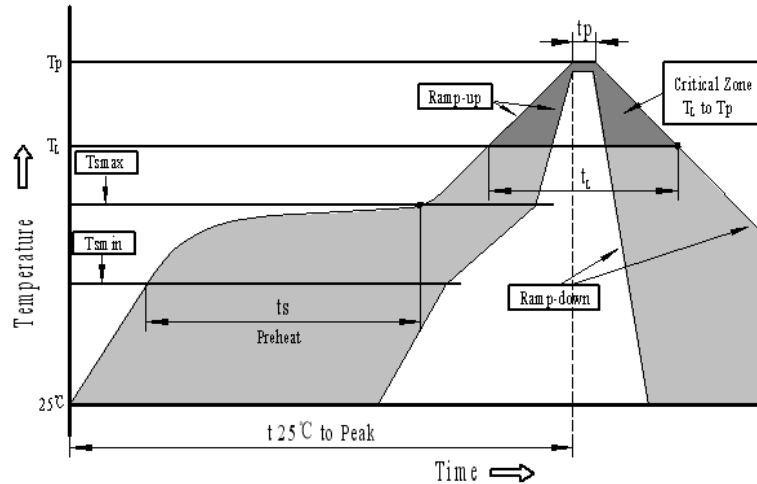

Profile Feature	Pb-Free Assembly
Average ramp-up rate (T_L to T_p)	3°C/second max.
Preheat	
-Temperature Min. (T_{Smin})	150°C
-Temperature Min. (T_{Smax})	200°C
-Temperature Min. (T_s)	60~180 seconds
T_{Smax} to T_L	
-Ramp-up Rate	3°C/second max.
Reflow	
- Temperature (T_L)	217°C
-Time (T_L)	60~150 seconds
Peak temperature (T_p)	250°C+0/-5°C
Time within 5°C of actual Peak temperature (T_p)	6 seconds max.
Ramp-down Rate	6°C/second max.
Time 25°C to Peak Temperature	8 minutes max.

Dimensions

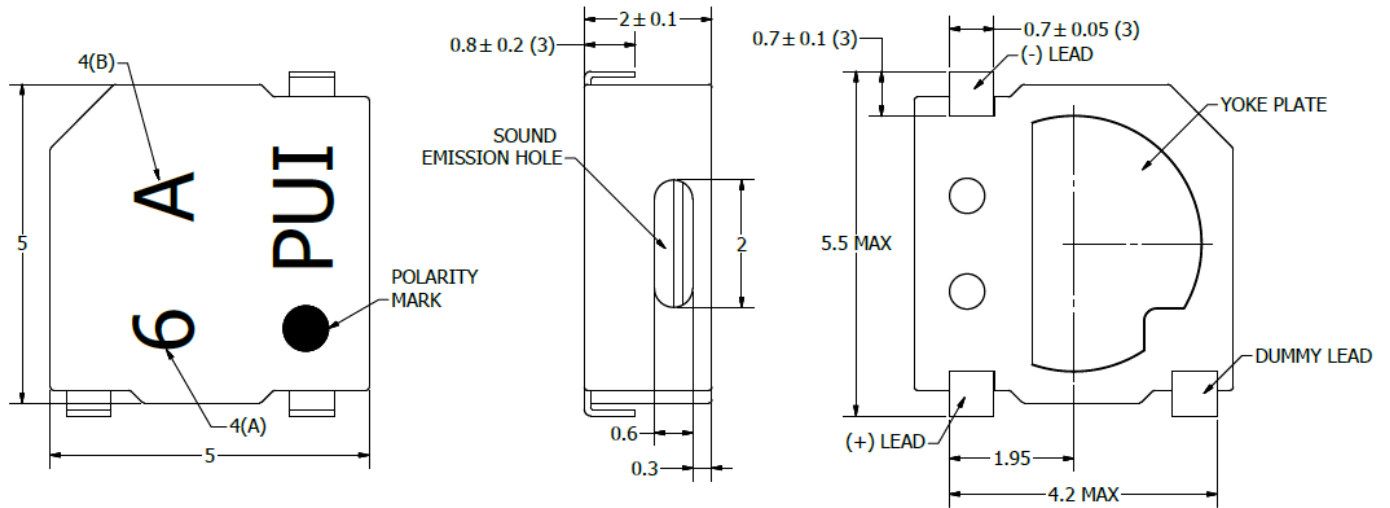

Tolerance $\pm 0.2\text{mm}$

Suggested Land Pattern*

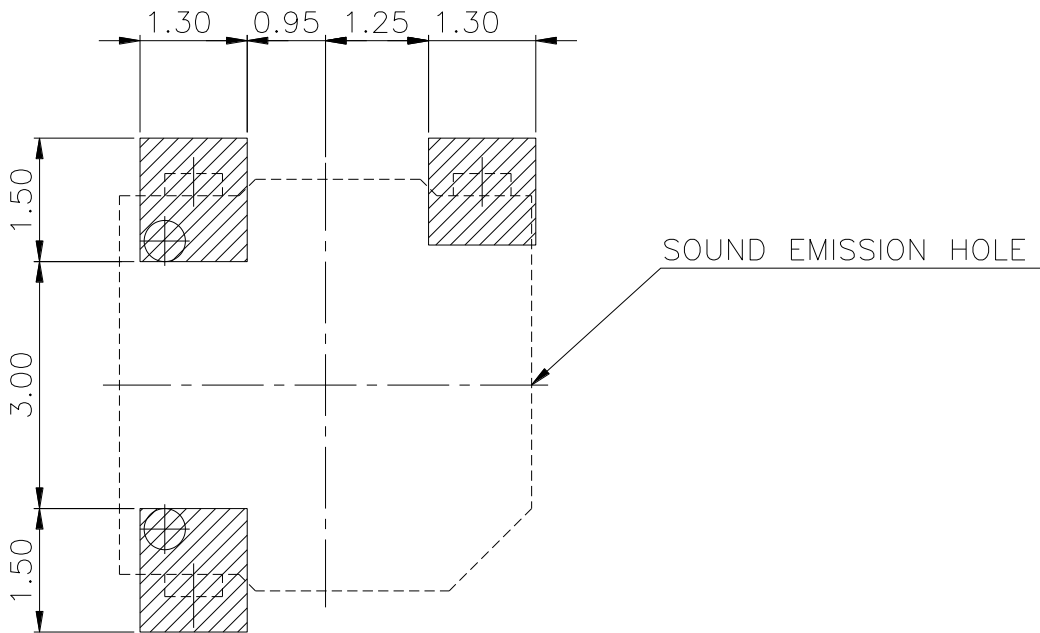

*This land pattern is advisory only and its use or adaptation is entirely voluntary. PUI Audio disclaims all liability of any kind associated with the use, application, or adaptation of this land pattern.

Packaging

2000pcs/Reel

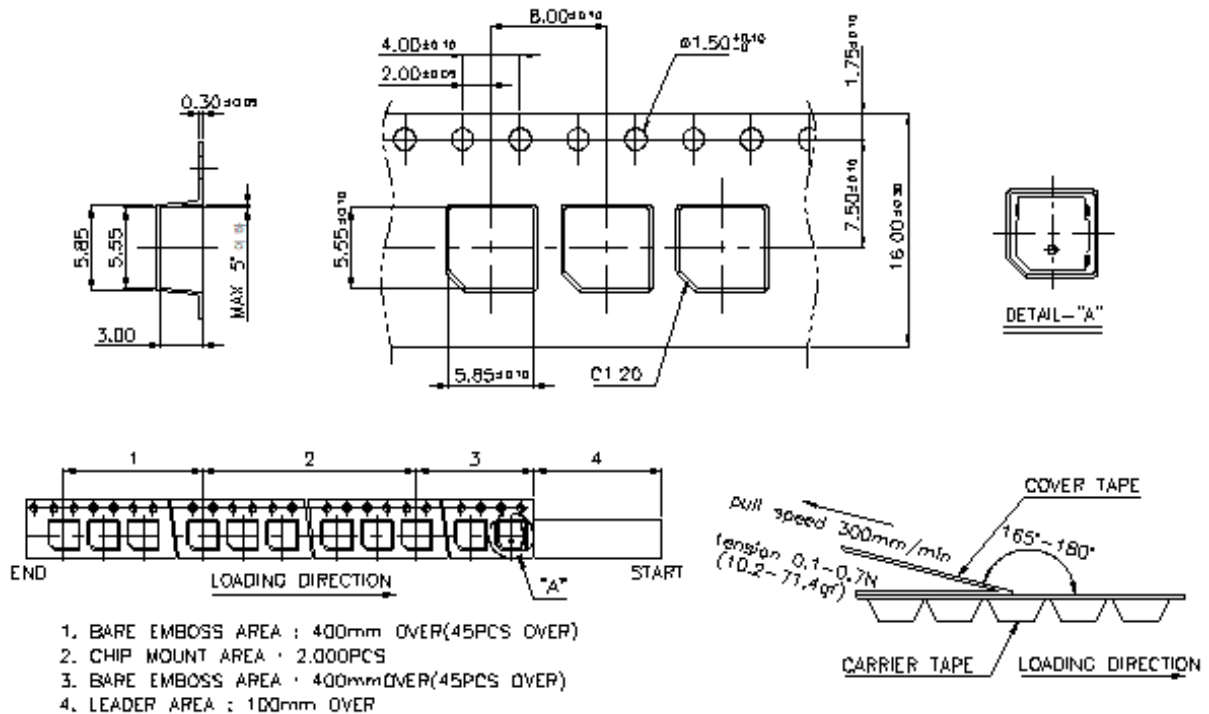
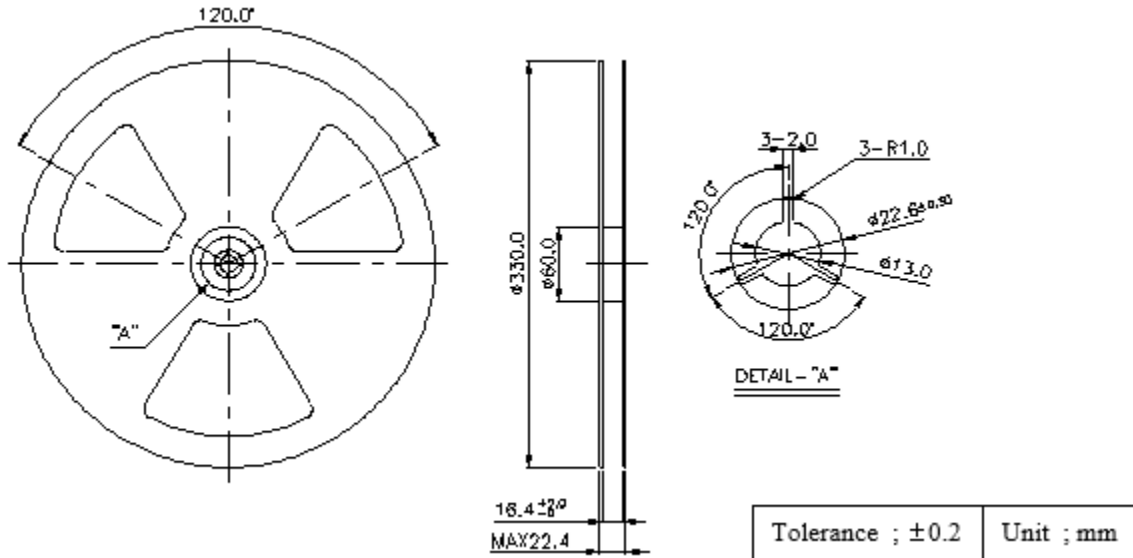

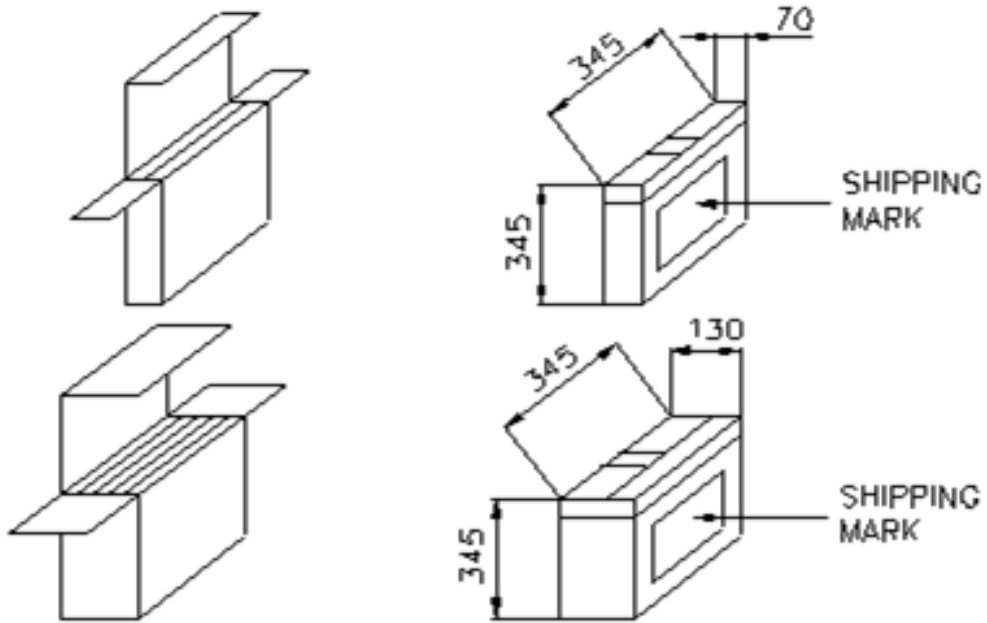

Specifications Revisions

Revision	Description	Date
-	Released from Engineering	03/31/2006
A	Revised to 3D Template	12/13/2007
B	Revised Tolerances on Dimensions	08/27/2010
C	Revised Lower Housing and Terminal Material	02/24/2011
D	Revised Voltage Units, Terminal Material, and Weight	02/28/2020

Note:

1. Unless otherwise specified:
 - A. All dimensions are in millimeters.
 - B. Default tolerances are $\pm 0.5\text{mm}$ and angles are $\pm 3^\circ$.
2. Specifications or changes may not be made without prior customer notification and approval.