

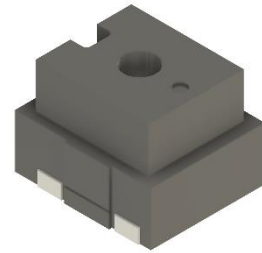

PUIaudio



Data Sheet

SMT-1720-T-HT

Features:

- High SPL of at least 95 dB at 10cm
- Broad Temperature range from -40°C to +105°C
- Surface mountable for ease of installation

Specifications

Parameters	Values	Units
Rated Voltage	12	V0-pk
Operating Voltage Range	8 ~ 16	V0-pk
Current Draw at Rated Voltage	50	mA
Coil Resistance	120 ± 15	Ohms
Minimum SPL @ 10cm	95	dBA
Resonant Frequency	2,000 ± 300	Hz
Housing Material	LCP	-
Terminal Material	Tin Plated Brass	-
Weight	3	Grams
Acceptable Soldering Methods	Reflow Solder	See page 2 for soldering information
Environmental Compliances	ROHS/REACH	-
Storage Temperature	-40 ~ 105	°C
Operating Temperature	-40 ~ 105	°C

Measurement Method (12V0-p ½ duty square wave)

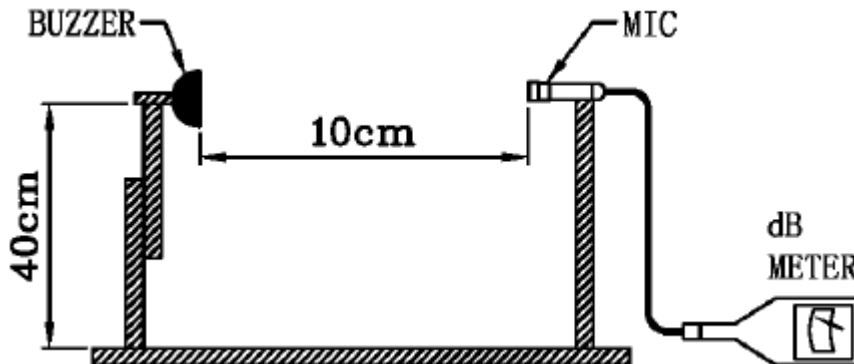

Typical Frequency Response (12V0-p 1/2 duty square wave)

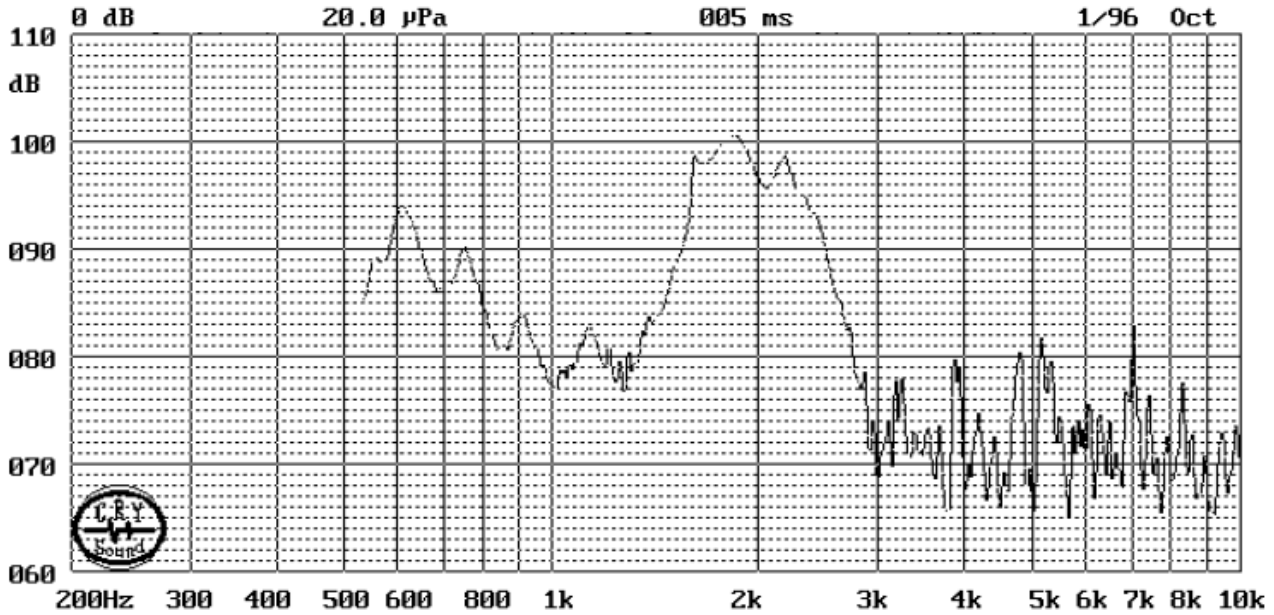

Recommended Soldering Procedure

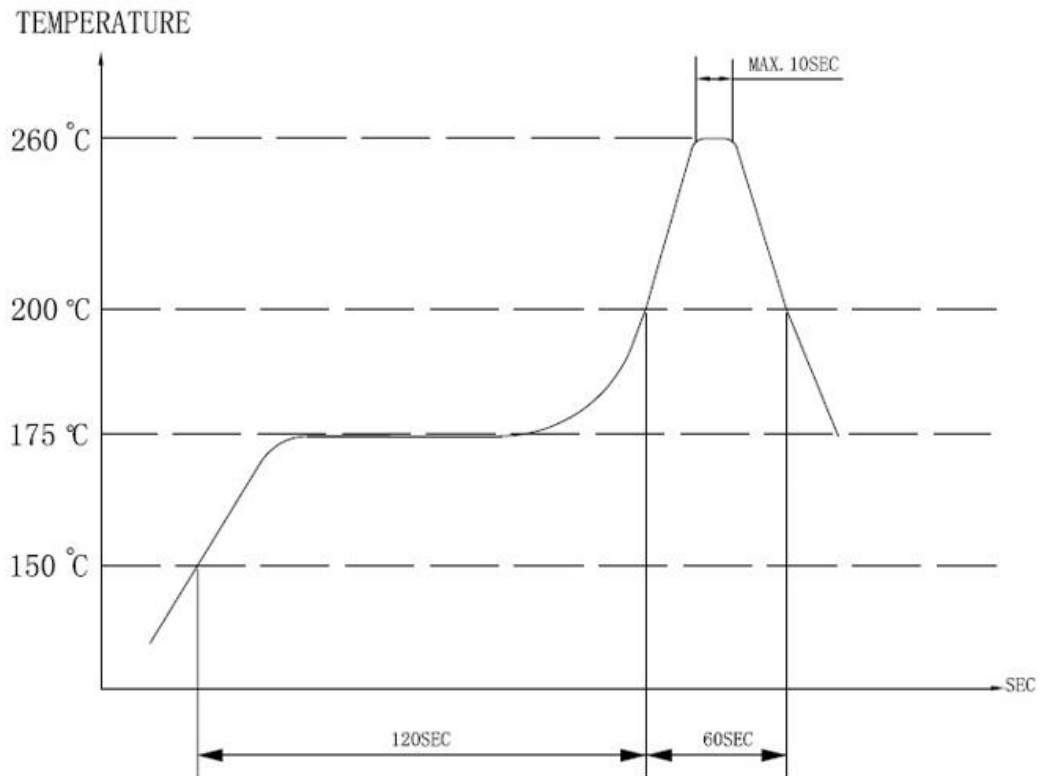

Heat resistant line

(Used when heat resistant reliability test is performed)

(2) Manual soldering

Manual soldering temperature 350 °C within 5 sec.

Reliability Testing

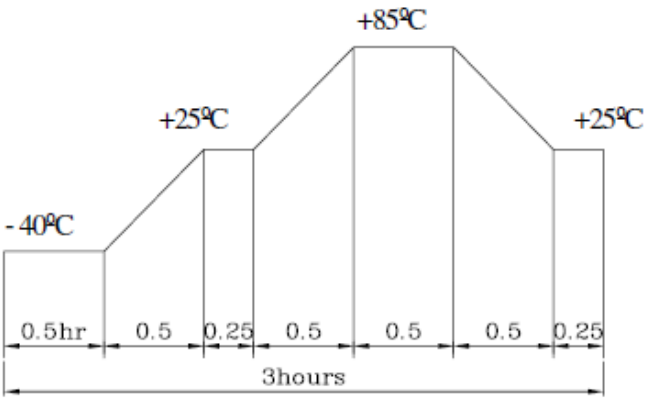
Type of Test	Test Specifications
High Temperature Test	96 hours at 85±2°C
Low Temperature Test	96 hours at -40±2°C
Humidity Test	96 hours at 40±2°C with relative humidity at 90~95%
Temperature Cycle Testing	<p>Run for 5 cycles with each cycle consisting of:</p>  <p>The diagram shows a temperature cycle profile over 3 hours. It starts at -40°C for 0.5 hours, ramps up to +25°C in 0.5 hours, dwells at +25°C for 0.25 hours, ramps up to +85°C in 0.5 hours, dwells at +85°C for 0.5 hours, ramps down to +25°C in 0.5 hours, dwells at +25°C for 0.25 hours, and finally ramps down to -40°C in 0.5 hours.</p>
Vibration Test	<p>Apply vibration of amplitude of 1.5mm with 10 to 55 Hz band of vibration frequency to each of 3 perpendicular directions for 2 hours</p>
Drop Test	Drop on a hard wood board of 4cm thick, any directions, 6 times, at the height of 75cm

After each test, let rest for 2 hours, then the change in SPL shall be within ±10dB

Dimensions

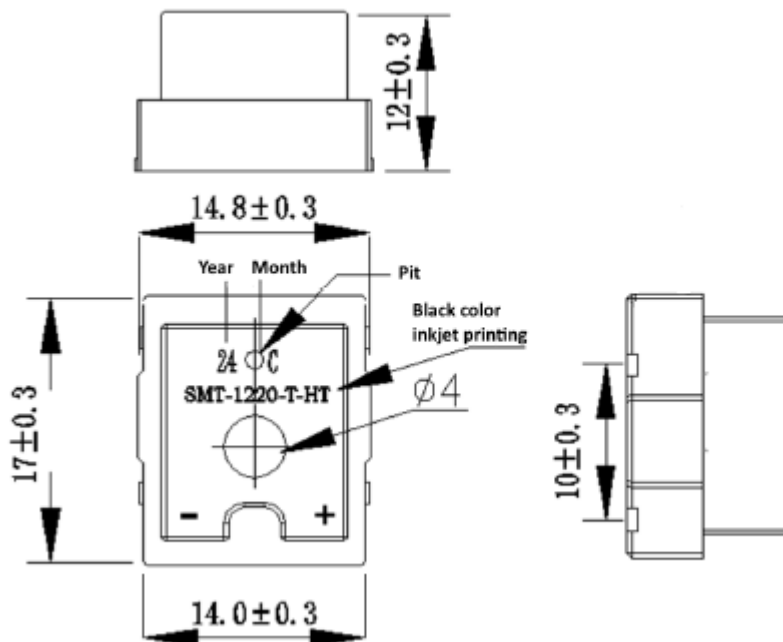

Suggested Land Pattern*

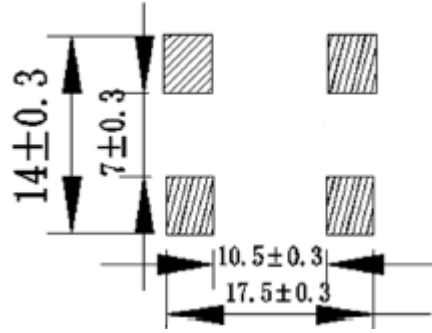

*This land pattern is advisory only and its use or adaptation is entirely voluntary.

PUI Audio disclaims all liability of any kind associated with the use, application, or adaptation of this land pattern.

Packaging

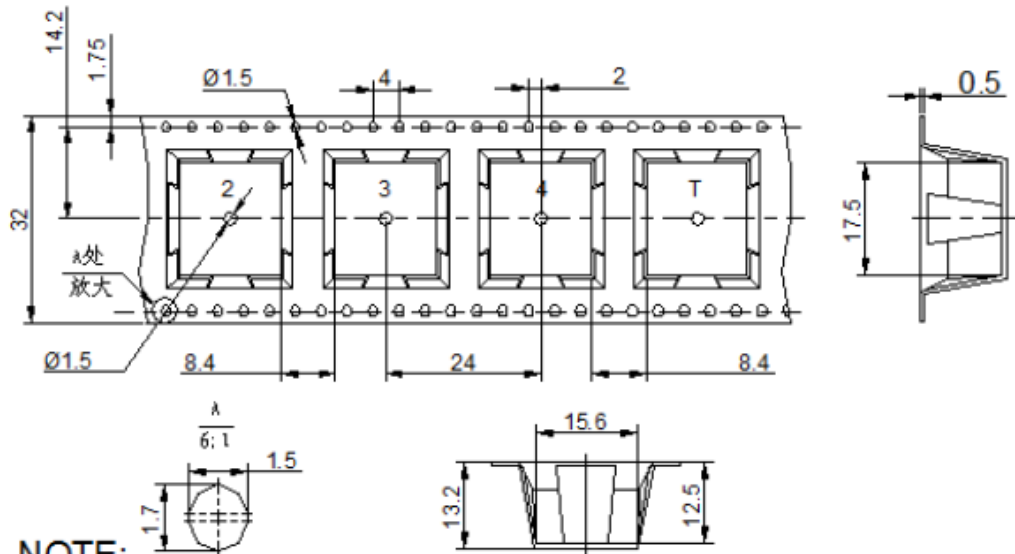

NOTE:

- 1.10 sprocket hole pitch cumulative tolerance ± 0.2 mm.
2. All dimensions meet EIA-481-D requirements.
3. Thickness: 0.5 ± 0.05 mm.
4. Component loaded per 15" reel: 200 pcs.

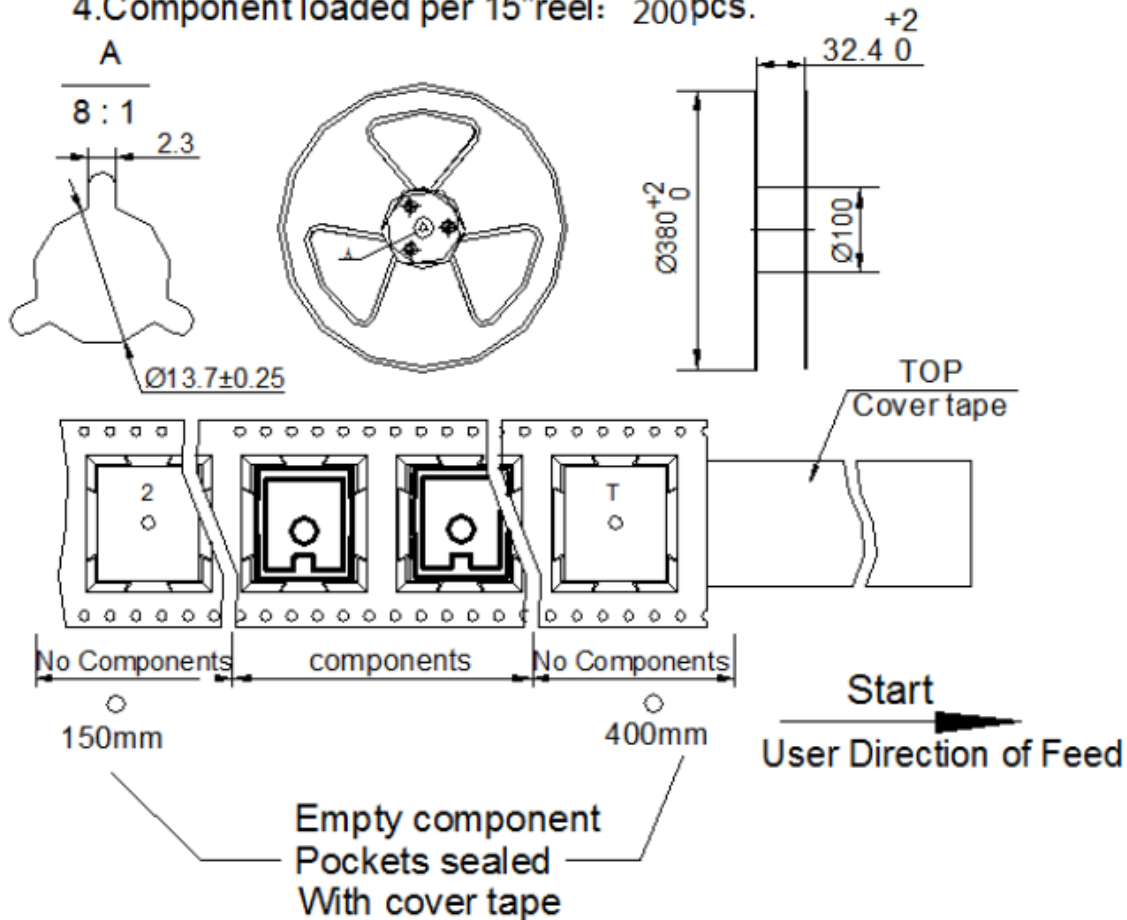

Specifications Revisions

Revision	Description	Date	Approved
A	Released from Engineering	5/31/2024	JD
B	Updated Packaging	7/31/2024	NK

Note:

- 1. Unless otherwise specified:
 - A. All dimensions are in millimeters.
 - B. Default tolerances are $\pm 0.5\text{mm}$ and angles are $\pm 3^\circ$.
- 2. Specifications subject to change or withdrawal without notice.